



VVG FASTENERS
A COMPANY OF THE HONSEL-GROUP

Perfect fastener solutions for industry and trade.

RivdomZERO

Rivsmart

small.light.compact.smart.



The new VVG battery riveters.

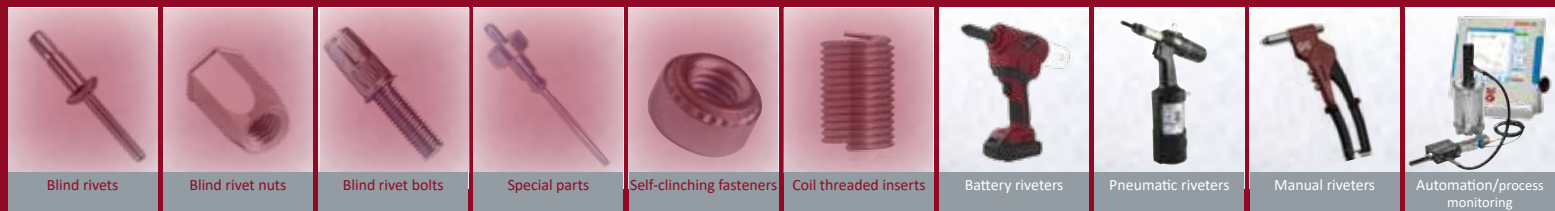

BLIND RIVET PROCESSING

For over **85 years**, we in the HONSEL Group have been successfully developing and producing **rivet and fastener technology** and are worldwide contacts for industry and trade.

We find reliable and optimised solutions for the needs of your application. A particular focus here is on the handling of individual, complex projects.

Our experienced **experts** in all areas have an open ear for your needs at all times and will be happy to advise you! **Online, by telephone or on site.**

The latest production facilities in Germany and Asia guarantee the **highest availability** of all standard article and **fast production** of special customised parts.

High-quality **fasteners**, advanced **processing tools** and fully automated and process-controlled **automation systems**
 – in our development departments, **innovative new products** and further developments are constantly being produced to complement and expand our product portfolio.

VVG. WE fasten it. For YOU.



In this edition ...

you can find a whole series of innovations in addition to the well-proven VVG range. Most notably with the

Rivdom ZERO

– the newest member of our battery riveter family.

A **weight of just 1.3 kg**, the wear-free **brushless motor** and practical **tool-free maintenance** are just a few of the features that you will like!



In the meantime, a constituent part of our range is made up of the **VVG StarCoil coil threaded inserts** that we also offer in the attractive **StarCoil boxes** in three sizes.

Just take a look at the options for **process monitoring with DMSD2G** of the current generation that can be used with both pneumatic riveters as well as with battery riveters.

On the following pages there is information on **sizes with national technical approvals** and our **free 3D data service** for designers and developers.

Please note this date in your calendars: The next **Fastener Fair** in Stuttgart from 19th -21st March 2019. You can find us there on Stand 1022 in Hall 1.

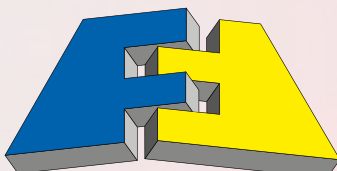

FASTENER FAIR

STUTTGART

The World's No.1

www.vvg.info



HONSEL Umformtechnik Fröndenberg



HONSEL 1965



New Works III in Fröndenberg (as of April 2018)

More than 85 years.

In 1930, Alfred Honsel founded the “Alfred Honsel Nieten- und Metallwarenfabrik GmbH & Co.” in Fröndenberg an der Ruhr that initially produced aluminium pots and pans whose handles were **attached with rivets**.

It quickly became clear: There’s great potential here. As early as **1945**, the production of household goods was discontinued completely and the company concentrated exclusively on the development and production of riveting technology.

By the **1960s**, HONSEL was already one of the leading manufacturers of brake and clutch pad rivets in Europe, and at the same time went into the production of blind rivets and rivet tools.

In the **1980s** the company began the development of blind rivet nuts, blind rivet bolts and pneumatic-hydraulic setting tools and their production.

In **1994**, the VVG-Befestigungstechnik was founded in Neumünster as a special trading company for riveting technology in order to be able to supply customers quickly and reliably

with the latest products from a well-stocked warehouse, and at the same time to make the know-how from many years of development and production available.

A concept for success. After several moves to different locations, the buildings at the current site in Neumünster were purchased in **2007**, creating the best boundary conditions for the further growth.

HONSEL has been producing more than a billion parts a year at a new works in Fröndenberg since **2003**.

The next expansion of the production facilities by 3500 m² to more than 10,000 m² and a new office building followed in **2014**.

The building of the third new works in Fröndenberg has now started that will go into operation in the second half of 2018 and will offer further space for production and fully automated logistics.

At the same time, a completely new workshop and service centre for processing components is being built at VVG in Neumünster.



VVG Befestigungstechnik Neumünster



HONSEL Fasteners Wuxi / China



VVG France in Frasné / France

Today

... the companies in the HONSEL Group offer an **all-embracing spectrum of rivet and fastener technology from a single source**. From the standard blind rivet through modern battery riveters or individually modified customised products right up to full automated and process-monitored processing units.

The companies are also successfully active in new product areas, such as **VVG StarCoil® threaded inserts** or the **HONSEL Powertrain Fasteners captive sleeve/stud system**.

HONSEL Umformtechnik in Fröndenberg is the production facility and development/sales location for special parts and automation solutions.

The whole range of standard and catalogue parts is marketed by **VVG Befestigungstechnik** in Neumünster where the new and further development of processing tools and the implementation of individual industry solutions is also centred.

VVG France in Frasné/France is responsible for the large French market.

The Group's activities are complemented by **HONSEL Fasteners** in Wuxi/China where, in addition to other production facilities, standard fasteners to HONSEL/VVG standard are manufactured and tested in a dedicated quality assurance centre. The site is also the logistics centre for Asia and delivers directly to the local Chinese market.

In addition, the Group works together with **sales and cooperation partners** in the USA, Asia, India, Australia, Brazil and many European countries, including the BeNeLux, Scandinavia, Poland, Italy, Switzerland or Turkey, in some cases for decades already, and can thus reach customers worldwide.



Design and development

The **continuous new and further development** of the HONSEL/VVG products plays a central role.

On the one hand, our application technicians and designers are permanently engaged in the **optimisation of the existing product range**.

Here they test, analyse, evaluate customer experience, correct, inspect and plan the feedback into the manufacturing at the various production sites.

This all happens against the background of an almost infinite basis of well-founded practical know-how from numerous decades during which HONSEL has been one of the pioneers in the development of innumerable products, particularly for blind rivet technology.

On the other hand, sophisticated ideas for **new products** evolve time and again in the minds of our engineers. We see ourselves as development partners for our customers who not seldom give us the stimulus for innovative and cost-efficient results.

Whether the variety of different fasteners, hand-held tools such as the successful **Rivdom** and **RivSmart** battery riveters or complex, fully automated industrial systems – we elaborate together with you and experienced technical consultants on site the individual, efficient, cost-effective – in short ... **the perfect solution for your application**.

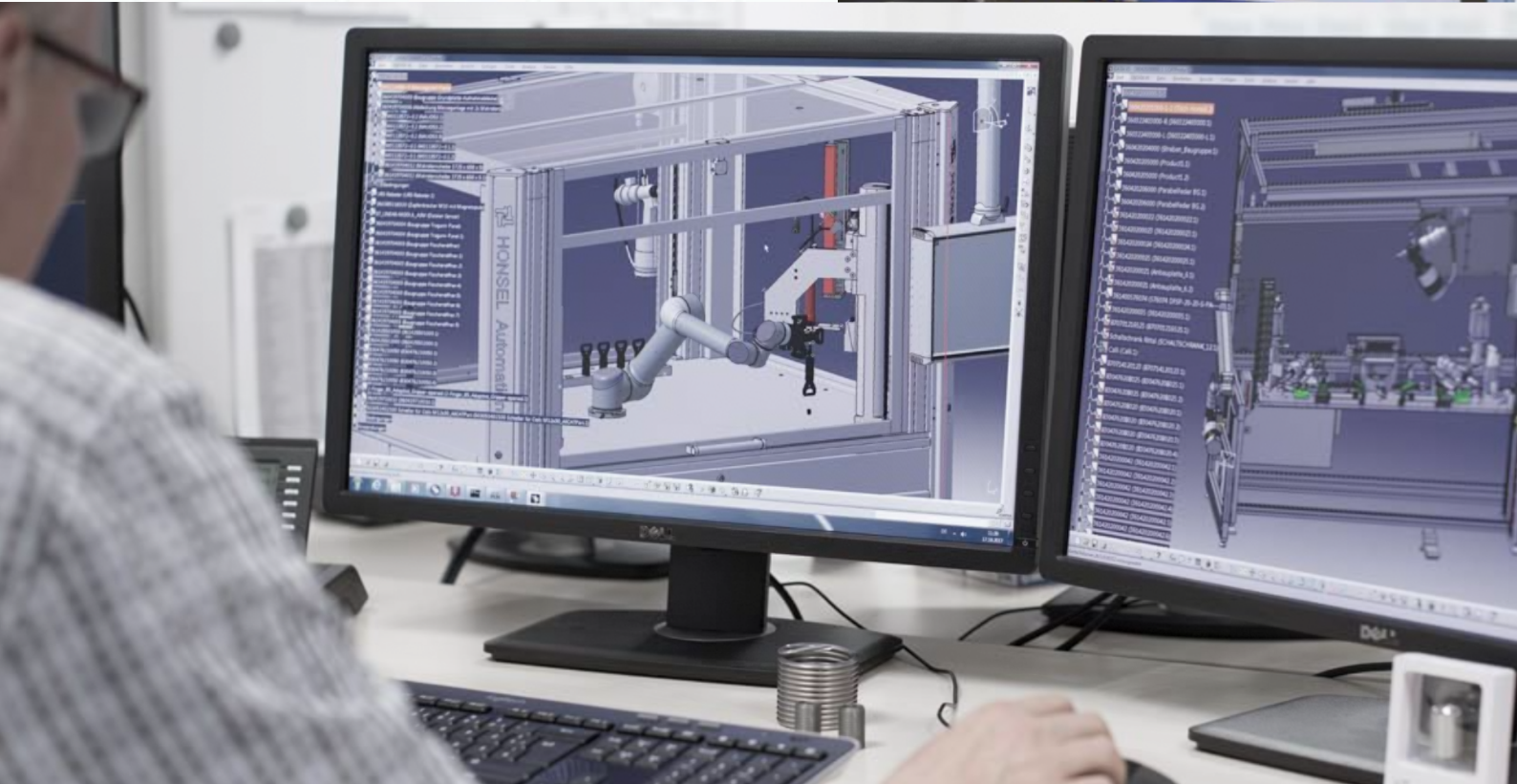
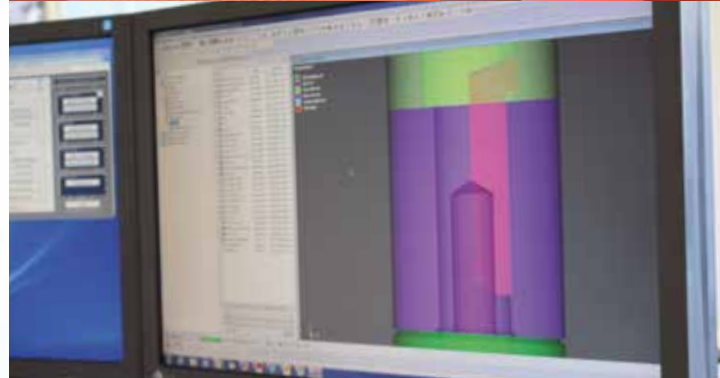
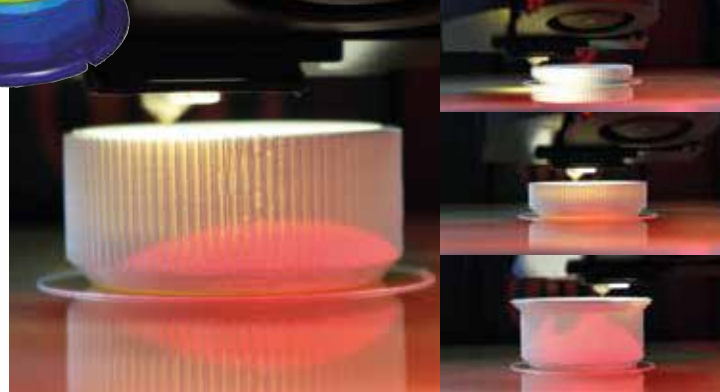
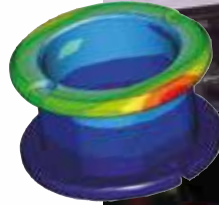
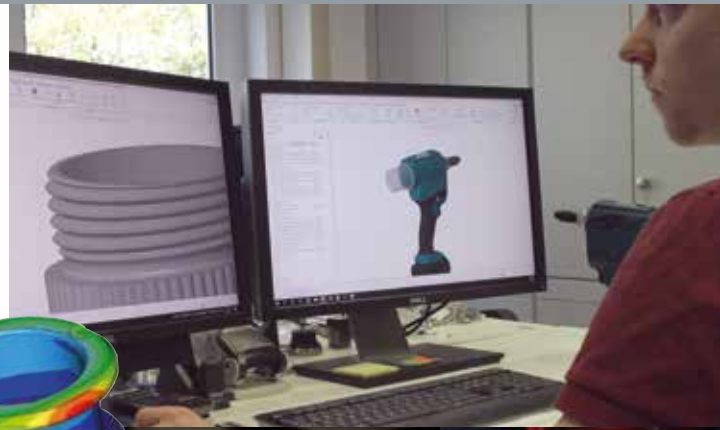



CAD data service

The right models for every CAD system.

We offer designers and product developers the opportunity of downloading each of our more than 1,300 standard sizes from the latest catalogue range for direct integration into their applications – in **over 100 different formats** as native 3D CAD models for all common CAD systems.

Simple, quick and free of charge.

They thus eliminate the need for time-consuming product searches or for requesting the necessary data material and can concentrate fully on their own development work.

Just find the required fastener as normal in the product section of our Internet website under www.vvg.info/produkte and then click on the CAD symbol behind the required size.



You either log in directly to the **CADENAS PARTcommunity** or simply create an account once only.

In the portal you then have the possibility of adapting the product to your demands again before the download and of selecting, for example, between delivery condition and finished rivet product.

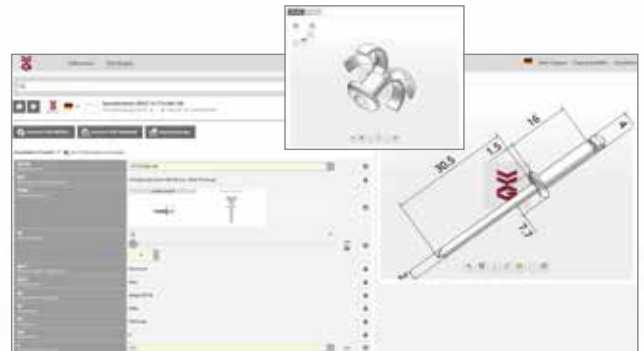



Production, further processing and toolmaking

Our manufacturing competence is the **complex cold forming of wire** in all common materials, such as steel, aluminium, stainless steel, copper and brass – **and many more**.

Pressing of the wire on a number of the latest **5-6 multistage headers** brings the **wire up to a diameter of 20 mm** into shape.

All presses are process-controlled and designed with redundancy. This guarantees sufficient flexibility to be able to meet even production demands at short notice.

The most important component, however, on which the **HONSEL** experience is based are **highly motivated staff** who are regularly trained and can successfully solve any task.

Pressing is often followed by a large number of further work steps:

Individual components are **laser welded** or **mechanically crimped**. A wide range of **threads** (male or female) are formed or **sealants are applied** (mechanically or injection moulded).

Certain contours can be modified by machining and even the application of special **partial scratch protection** coatings is possible.



Particular attention has been paid for many years to investments in future-oriented technologies and the machine park, and specially in our **in-house toolmaking shop**. The in-house production of the necessary manufacturing tools guarantees **reduced delivery times up to series maturity** and vast possibilities for **meeting even unusual wishes of our customers**. The complex tool kits often comprising several hundred parts are stored in a perfectly organised and fully automated system, and are therefore quickly available for use on the machines at any time.

In order to be able to carry out central production processes in-house, HONSEL has amassed vast know-how in a very wide range of **heat treatment technologies** and is therefore able to modify lightweight materials in such a way that their strength is significantly higher than normal in some areas.

Finishing operations such as barrel finishing, drilling, turning and milling, rolling and pointing or the assembly of component elements are also performed in-house.



Quality

Quality in every form has the greatest importance in our day-to-day business activities.

100 % inspection and **0 ppm strategies** are criteria that companies have to meet today when it comes to defining targets in quality assurance.

The HONSEL Group has made very significant investments in this area in recent years and **developed exemplary quality assurance processes**. This is underlined by our certification to ISO 9001:2008, ISO 14001 and ISO/TS 16949.

In addition to standard test methods for checking shear and tensile forces, the riveting mandrel breaking forces and push-out forces and the locking of the mandrel inside the head, the latest measuring instruments and testing facilities ensure the highest level of production even with very large quantities. Here we use **process monitoring systems** and **optoelectronic testing machines** developed in-house for the individual 100 % inspection.

By **already testing every individual batch at all phases of the running production process** and its documentation by means of a CAQ software integrated into our modern IT system, continuous tracking of all shipped products is assured back to the starting material used.

Measuring equipment is also available for length and roughness tests, metallurgical tests, microscopy, profile projection, eddy current and hardness tests.

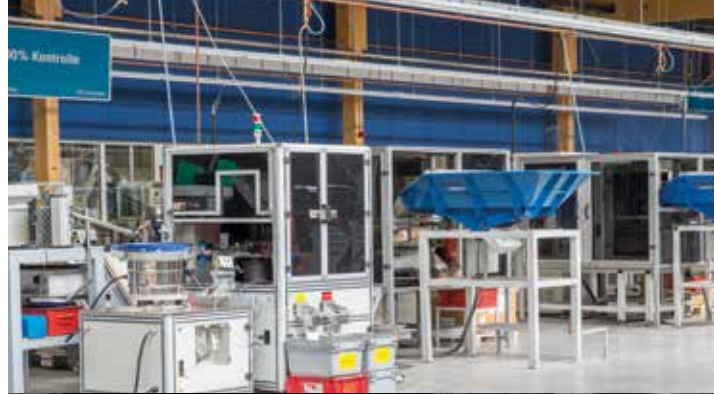
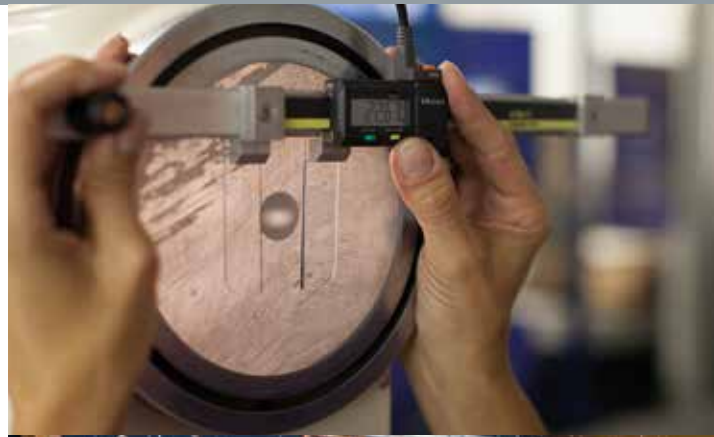



National technical approvals

General national technical approvals are required for many types of construction and construction products where no defined rules and standards exist, or where extreme deviations from these exist.

These serve as proof of their safe use in the intended applications and describe the necessary technical requirements for a construction.

In the field of blind rivet technology, for example, these are:

- General fasteners for steel and aluminium substructures
- Aluminium substructures for solar energy installations
- Longitudinal butt joints of corrugated sheets
- Longitudinal butt joints of metal and corrugated plastic sheets
- Production of sliding points on aluminium substructures



The blind rivets currently approved or undergoing the approval process from the product groups **ALFO®**, **OPTO®**, **CERTO®** and for **folding blind rivets with neoprene seal** are marked with the symbol opposite.

For necessary documents and further information, please contact the specialists from our technical sales team directly.



Certificates



You can rely on us. Guaranteed.

Please ask for possible updated versions of the certificates issued during the life of the catalogue.



Logistics

Quick and reliable delivery of the ordered goods is one of the hallmarks of our company.

In addition to long contact hours, late last shipping time and short organisational and spatial routes, our long-standing cooperation partner UPS guarantees smooth handling for the transport of the shipments – with next-day delivery, of course, where necessary.

Shipping of palletized goods by shipping company – no problem, because here again we work only with experienced companies who guarantee punctual delivery.

The goods leave our company safely packed and clearly marked so that they reach you correctly and undamaged.

Via our logistics centre, we ship **more than 50,000 packets and 5,000 pallets every year** worldwide.

Well over 10,000 m² of logistics and warehousing area are available at all locations with space for articles in sales packagings, loose bulk materials, wire coils for production and thousands of pallet storage locations, as well as separate commissioning areas and covered loading zones.

In addition to the current catalogue articles, we have tens of thousands of further articles and variants waiting for you in our warehouse, and can thus ensure a supply capability of at least 98 %.

Our modern packaging facilities offer capacities for even the largest volumes. Within a minimum of time, we can fill cartons of all sizes, individual customer packagings, individual bags or the industrially employed small load carriers (KLTs).

The whole logistics process is IT-aided. Scanners and tablet PCs are just as much part and parcel of day-to-day life in order commissioning as EDI and other data interfaces for smooth communication with customers and service providers.



Advice

Product know-how and application experience are part of our DNA.

Our employees in all departments can call on the vast know-how developed over the **more than 85 years** of the company history.

This, and the ongoing in-house and external further training, ensures that outstandingly qualified and motivated staff are ready to competently answer all your questions surrounding the topic of “riveting technology”.

We accompany special projects from the first idea through to the final delivery with experts from all the necessary department who work closely together to **guarantee optimum handling**.

We'll come to you.

On site, our technical application consultants are available with advice and support throughout Germany.

Detailed demonstrations and intensive advise together with **comprehensive training** are indispensable aspects of the successful cooperation with our customers.

At **in-house fairs** or during special information days as part of the “Riveting Technology on Tour” campaigns that we have successfully organised for many years on our retail partners' premises throughout Germany, our experts present all the products from our portfolio.

Furthermore, you can meet us regularly at a wide range of **trade fairs** in Germany and abroad.

There we provide information on both innovations and our classic products. It is not unusual for the discussions held here to lead to interesting suggestions and ideas from practical use that we integrate into our product portfolio.

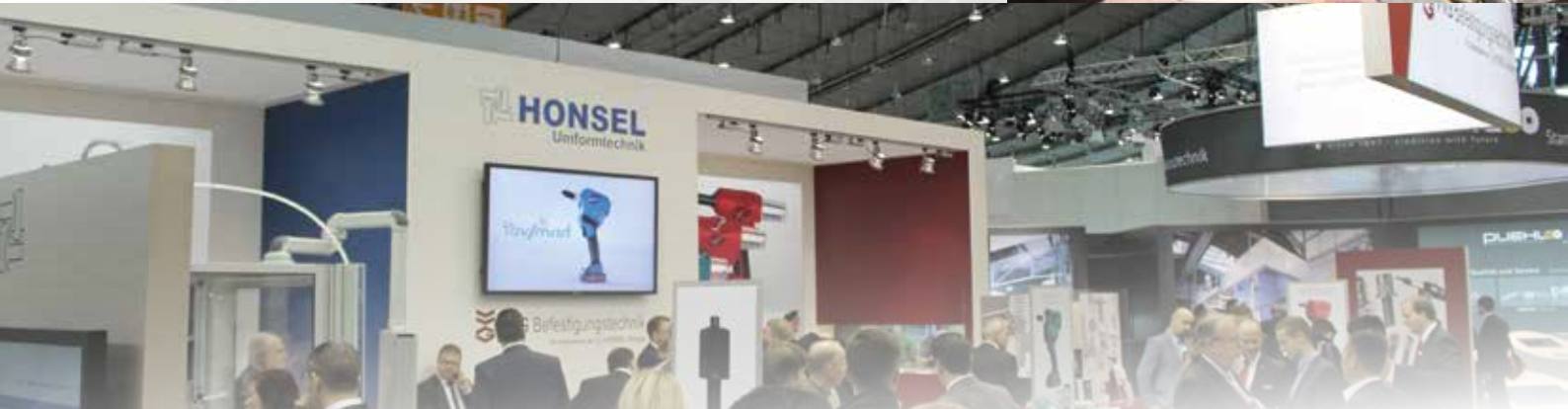



Service

In addition to our high-quality products, as system supplier for rivet and fastener technology we also offer a comprehensive “**all-round service**”.

In order to guarantee **maximum contact hours** for our customers, our customer support staff in Sales can be reached **from Monday to Thursday from 7.00 a.m. until 5.00 p.m. and on Friday until 4.00 p.m.**



Orders reaching us on workdays by 3.00 p.m. are shipped **on the same day** on request. The required goods can be at their destination the following day with standard shipment – guaranteeing you high flexibility in your order planning.

Within the framework of skeleton contract, we produce and stock the goods for you and ship them automatically and reliably to the point of use **just in time** according to an agreed delivery plan.

We offer our retail partners a variety of different **sales support materials**, for example in the form of catalogues and flyers, that can also be individually designed on request. In addition, we advise you during the presentation of our products in your shop.

Our **Rivet Processing Competence Centre** (► **PAGE 160**) is available for the maintenance and repair of all VVG/HONSEL tools.

Here our staff ensure that tools sent in are ready for use again within a minimum of time.

And in order that there is no loss of production, we can provide you with a **hire tool** on request.





Online

Visit us regularly on the Internet!

On our website www.vvg.info/en you will find not only information about the company group, but also a number of useful tips to simplify your day-to-day work in rivet and fastener technology.

The heart of the website is the extensive, convenient **product search**. Here you will quickly and easily find the desired product from our current catalogue assortment with photo, drawings, in many cases film or animation, technical data, PDF data sheets, tool recommendations and CAD data for the design engineering (► [PAGE 7](#)).

In addition, we offer a wide range of material such as product flyers or illustrative materials for your sales activities in the **Download Centre**, a convenient **product viewer** for finding tool spare parts and a **live chat** as a quick and direct link to our team.

Further information on the Group can be found at:
www.rivsmart.com (battery riveters with smart technology)
www.honsel.de/en (HONSEL Umformtechnik. wire products)
www.honsel-automation.de/en (New in 2018 – Industrial Automation)

The pages can also be used easily and intuitively on all mobile devices.

On the two **YouTube** channels we have a large number of films and animations explaining our products that can also be called up via the **QR codes** in this catalogue.

Up-to-date information can also be found constantly, for example, on **facebook** or **twitter** and further social media platforms.



www.vvg.info/en



www.honsel.de/en



www.rivsmart.com



www.honsel-automation.com



www.youtube.com/nietweltdigital



www.youtube.com/honselumformtechnik



VVG Befestigungstechnik



Blindnieten
Perfektion.

RivSmart - Klein, Leicht, Smart

Information and explanation of symbols

Article numbers / allocation to tools:

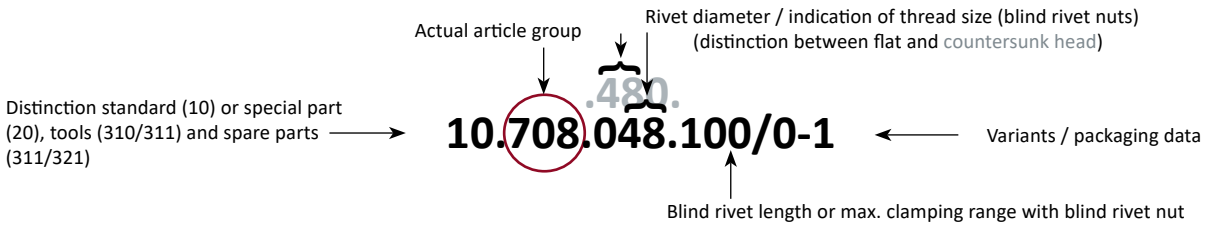

Info block
with additional information / icons

Article group designation
with materials and version

Figures
with product photo, drawings and material details

Tabs
for better orientation when the catalogue is closed

Table – basic data
diameter / length / clamping range / article no. / packaging size / price

Table – additional information
head + shank diameter, head height, bore diameter, various force data

ALFO® Standard Blind Rivet
Stainless Steel A2 → Stainless Steel A2
Dome Head | open

QR code | FILM | DIN EN ISO 15983 | CAD DATA ONLINE | Series 708

d	l	⌀	Nr.	⊞
2,4	6,0	0,5 - 3,5	10.708.024.060	500
	8,0	3,0 - 5,5	10.708.024.080	500
⌀ _h 5,0 - ⌀ _h 2,5 k 0,8 - ⌀ _h 1,5 2,5 mm → 1000 N → 1500 N				
3,0	6,0	0,5 - 3,0	10.708.030.060	500
	8,0	3,0 - 5,0	10.708.030.080	500
	10,0	5,0 - 7,0	10.708.030.100	500
	12,0	6,5 - 8,5	10.708.030.120	500
16,0	8,5 - 12,0	10.708.030.160	500	
⌀ _h 6,3 - ⌀ _h 1,9 k 0,8 - ⌀ _h 2,7 3,1 mm → 2050 N → 2600 N				
6,0	0,5 - 3,0	10.708.032.060	500	
8,0	3,0 - 5,0	10.708.032.080	500	
10,0	5,0 - 7,0	10.708.032.100	500	

d	l	⌀	Nr.	⊞
4,8	8,0	1,5 - 4,0	10.708.048.080	500
	10,0	4,0 - 6,0	10.708.048.100	500
	12,0	6,0 - 8,0	10.708.048.120	500
	14,0	7,0 - 9,5	10.708.048.140	500
16,0	8,0 - 11,0	10.708.048.160	500	
18,0	11,0 - 13,0	10.708.048.180	500	
20,0	13,0 - 16,0	10.708.048.200	500	
⌀ _h 9,5 - ⌀ _h 2,9 k 1,1 - ⌀ _h 3,5 4,4 mm → 4250 N → 5400 N				
8,0	2,0 - 4,0	10.708.050.080	500	
10,0	4,0 - 6,0	10.708.050.100	500	
12,0	6,0 - 8,0	10.708.050.120	500	
14,0	7,0 - 9,5	10.708.050.140	500	

Colour coding system

An unambiguous colour is assigned to each material that can be found also in both the navigation bar and the production designations and drawings as an aid to orientation. Furthermore, the colours are also integrated into the representation of the processing possibilities of all the tools. In addition, you will find the colour coding on a large proportion of our labels.

- Steel
- Stainless steel
- Aluminium
- Copper
- Bronze

	M3	M4	M5	M6	M8	M10	M12
Aluminium							
Steel							
Stainless steel							



ICONS

- General product information
Useful information on further dimensions, variants or special features and cross-references
- Page references
- VVG Serial No.
- CAD data available online
- DIN EN ISO
- QR code with content information

- Clamping range
- Shear breaking force
- Tensile breaking force
- Tightening torque
- Axial tensile force
- Bore diameter

Required information for your order / enquiry

Blind rivets

- Material combination (sleeve / mandrel)
- Shaft / bore diameter (d)
- Shaft length / clamping range (l)
- Head form (flat, countersunk, large dome head)

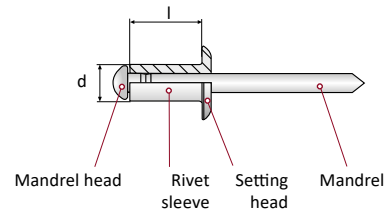

Blind rivet nuts / bolts

- Material
- Thread size (M)
- Shaft / bore diameter (d)
- Shaft length / clamping range (l)
- Shaft form (open / closed)
- Head form (flat, countersunk, small countersunk head)
- Twist lock (knurling / (partial) hexagonal shank)
- Bolt length in set condition (l₂)

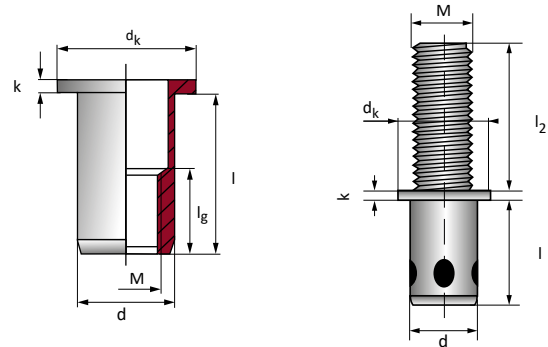

Tools

- **How often is the tool used?**
No. of rivets
- **Where is the tool used?**
Production / workshop / construction site, etc.
- **What max. dimensions / materials are processed?**
- **Are special rivet types to be processed?**
e.g. high-strength blind rivets



Please note

that a very large number of individual factors have an influence on a riveted joint. For this reason, riveting tests should always be performed (we can provide samples for these on request).

The standard range presented in this catalogue shows only a small proportion of all the products available. Should you not find an article or size – we'll find an alternative!



Special nosepiece required



Hexagonal product



Closed shaft



knurled

Imperial dimensions



Stainless steel A4 grade



Pivoting tool head



Weight in kg



Tensile force at 7 bar



Pressure in bar



Stroke in mm



Maximum stud diameter



Sound emissions in dB(A)



Air consumption in litres



Connection possibilities



Scope of delivery



Type of packaging



Packaging with hole for hanging

Blind Rivets



ALFO® Dome Head



ALFO® Countersunk Head



ALFO® Large Dome Head



ALFO® grooved



Painted / head painted / anodized



OPTO® Multigrip Different Head Shapes



CERTO® Seales Blind Rivet Dome or Countersunk head



HIGH-STRENGTH FERRO®-BOLT Dome or Countersunk head



HIGH-STRENGTH FERRO®-BULB Dome Head



Folding Blind Rivet Special



HIGH-STRENGTH OPTO®-BULB Dome Head



CERTO® PERFECT Dome Head



Hammer Stroke



Grounding

Blind Rivet Nuts



Round Shank Flat Head



Round Shank Countersunk Head



Round Shank



Folding Blind Rivet Nut



Hollow Blind Rivet Nut



OPTO® Multigrip



HEXAFORM® Hexagonal



HEXATOP® Patial Hexagonal



Blind closed

For more information about these product groups see our separate catalogs or visit our website www.vvg.info/en

Blind Rivet Bolts



RIFBOLT® Flat Head



RIFBOLT® Countersunk Head



RIFBOLT® Small Countersunk Head



RIFBOLT® Hexagonal

Einpressbefestiger



Self Clinching Nuts



Self Clinching Rivet Nuts



Self Clinching Studs



Self-Clinching Stand-Offs

Drahtgewindeeinsätze



VVG StarCoil



VVG StarCoilBoxes



Hand Tools



BZ Series for Blind Rivets



BZ 2 BZ 44 BZ 6



BZ 70 / BZ 72 BZ 58

VNG Series for Blind Rivets Nuts and Bolts



VNG 255 VNG 612
VNG 371 VNG 152

MULTI series for Blind Rivets, Blind Rivet Nuts and Bolts



MULTI 1 MULTI 5

Battery Tools



Rivdom ZERO^{12V} Rivdom ONE^{16V} Rivdom TWO^{20V} RivSmart

Pneumatic-hydraulic Tools



DMSD Process monitoring



BZ series for Blind Rivets



BZ 103 A BZ 123 A BZ 133 A BZ 143 A

VNG for Blind Rivets Nuts and Bolts



VNG 703 (force-controlled) VNG 903 (stroke-controlled) VNG 753 (for Folding Blind Rivet Nuts)

Blind Rivet Nuts

Blind Rivet Bolts

Self Clinching Fasteners

Drahtgewindeeinsätze

Processing / Tools

20

Hand tools	Page 26
Battery tools	Page 44
Pneumatic-hydraulic tools	Page 70

HONSEL Umformtechnik

226

Automation Page 230



Sturdy handriveting tools



Battery-powered riveting tools of the latest generation



Advanced and reliable pneumatic riveting tools



Individually constructed process

Details on pages 230/231

BZ



BLIND RIVETS

BZ tools are all about the working of the classical blind rivet in all its varieties. The BZ series is available as hand, lever or lazy tong pliers, as well as pneumatic-hydraulic operated tools.

VNG



BLIND RIVET NUTS and BLIND RIVET BOLTS

VNG tools can set blind rivet nuts as well as RIFBOLT blind rivet threaded bolts. They are available as hand or lever pliers, as well as pneumatic-hydraulic operated tools.



Multi



**BLIND RIVETS, BLIND RIVET NUTS
and BLIND RIVET BOLTS**

The MULTIS can do anything. All three blind rivet products are workable with only one tool!

Multi-functional tools are exclusively available as hand or lever pliers in our program.

Rivdom RivSmart

**BATTERY RIVETER
CONVENIENT. SMALL. LIGHT. SMART.**

Rivdom and **RivSmart** – our two product lines for battery riveters MADE BY HONSEL. **Rivdom** offers the latest technology with a wide range of useful details. **RivSmart** impresses with its smart control – perfect for industrial applications.

RIVETING FROM A TO Z – FROM A SINGLE SOURCE.



The perfect processing of our connectors is one of our core competences. **For decades.**

We develop **new ideas** every day. Creative, with a great deal of know-how, leaving the beaten path and taking the feedback from our customers, our technical sales and service team into consideration.

After evaluation of the feasibility, implementation is carried out by **experienced design engineers** at modern CAD workstations, in prototype production and in-house 24/7 endurance tests on several plants with widely differing boundary conditions. **Assembly or production** and its permanent monitoring and optimisation takes place exclusively at Group sites.

The best examples are the successful **Rivdom®**- and new since 2017 **RivSmart®** battery riveters with their innovative details and extensive options.

In our **service workshop**, trained staff take care of the **fast repair of all tools**, from blind rivet hand tools, through battery riveters right up to pneumatic tools and automation components. Here the outstanding equipment in the workshop and very large stocks of thousands of spare parts guarantee that our repair professionals solve even the most complicated cases quickly so that your production has no standstill times. If necessary, we can fall back on a large pool of **loan equipment**.

Preventive **maintenance** is also playing an increasingly important role. Talk to our sales staff about the possibilities of extended guarantees, maintenance plans and service packages.



ONLINE CHECK-IN

Take advantage of the ONLINE CHECK-IN for repairs and maintenance on our Internet website.



At present, a new and greatly enlarged workshop and training centre is being built at our Neumünster site.



Very special. Customised. Just YOU.

Use our quality tools completely in your corporate design. Impress your customers with your "own" tool, boost your sales and you increase the customer loyalty to your brand.

With a private label product you get your tools in your house colours with your logo and your name, also with labels (if necessary) and an individual packaging design and operating manual.

We can provide professional support here. Experienced project planning, design to your specifications, sampling, long-term delivery plans and, on request, the handling of service and maintenance by our Rivet Processing Competence Centre simplify the implementation for you.



Your ...
LABELS
TOOL COLOUR
PACKAGING
MANUAL



Talk to us – we will inform you about minimum quantities and boundary conditions and develop your rivet tool series together with you.

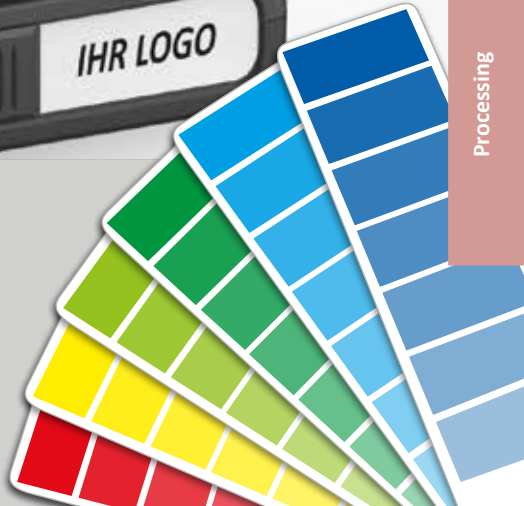

Processing

HANDLING OVERVIEW BLIND RIVET ...

■ Aluminium
 ■ Steel
 ■ Stainless Steel
 ■ Copper Alloys



BZ blind rivet hand tools

	Blind rivets										
	2,4	3,0	3,2	4,0	4,8	4,8 high strength	5,0	6,0	6,4	6,4 high strength	8,0
BZ 2	■	■ ■ ■ ■	■ ■ ■ ■	■ ■ ■ ■	■ ■ ■ ■		■				
BZ 6	■	■ ■ ■ ■	■ ■ ■ ■	■ ■ ■ ■	■ ■ ■ ■		■				
BZ 44	■	■ ■ ■ ■	■ ■ ■ ■	■ ■ ■ ■	■ ■ ■ ■		■				
BZ 58		■ ■ ■ ■	■ ■ ■ ■	■ ■ ■ ■	■ ■ ■ ■		■ ■ ■ ■	■		■	
BZ 70		■ ■ ■ ■	■ ■ ■ ■	■ ■ ■ ■	■ ■ ■ ■	■	■ ■ ■ ■	■			
BZ 72				■ ■ ■ ■	■ ■ ■ ■	■ ■ ■ ■	■ ■ ■ ■	■ ■ ■ ■	■ ■ ■ ■	■ ■ ■ ■	■

MULTI hand tools

	Blind rivets										
	2,4	3,0	3,2	4,0	4,8	4,8 high strength	5,0	6,0	6,4	6,4 high strength	8,0
Multi 1	■	■ ■ ■ ■	■ ■ ■ ■	■ ■ ■ ■	■ ■ ■ ■		■				
Multi 5		■ ■ ■ ■	■ ■ ■ ■	■ ■ ■ ■	■ ■ ■ ■		■ ■ ■ ■	■ ■ ■ ■	■ ■ ■ ■		

BZ blind rivet tools (pneumatic-hydraulic)

	Blind rivets										
	2,4	3,0	3,2	4,0	4,8	4,8 high strength	5,0	6,0	6,4	6,4 high strength	8,0
BZ 103A	■	■ ■ ■ ■	■ ■ ■ ■	■ ■ ■ ■	■ ■ ■ ■	■ ■ ■ ■	■ ■ ■ ■				
BZ 123A				■ ■ ■ ■	■ ■ ■ ■	■ ■ ■ ■	■ ■ ■ ■	■ ■ ■ ■	■ ■ ■ ■	■ ■ ■ ■	■ ■ ■ ■
BZ 133A					■ ■ ■ ■	■ ■ ■ ■	■ ■ ■ ■	■ ■ ■ ■	■ ■ ■ ■	■ ■ ■ ■	■ ■ ■ ■
BZ 143A										■ ■ ■ ■	■ ■ ■ ■

Rivdom/RivSmart blind rivet tools (battery-powered)

	Blind rivets										
	2,4	3,0	3,2	4,0	4,8	4,8 high strength	5,0	6,0	6,4	6,4 high strength	8,0
RivdomZERO ^{12V}	■ ■ ■ ■	■ ■ ■ ■	■ ■ ■ ■	■ ■ ■ ■	■ ■ ■ ■	■ ■ ■ ■	■ ■ ■ ■				
RivdomONE ^{16V}	■	■ ■ ■ ■	■ ■ ■ ■	■ ■ ■ ■	■ ■ ■ ■	■ ■ ■ ■	■ ■ ■ ■				
RivdomTWO ^{20V}				■ ■ ■ ■	■ ■ ■ ■	■ ■ ■ ■	■ ■ ■ ■	■ ■ ■ ■	■ ■ ■ ■	■ ■ ■ ■	
RivdomTWO.8 ^{20V}										■ ■ ■ ■	■ ■ ■ ■
RivSmart ^{12V}	■ ■ ■ ■	■ ■ ■ ■	■ ■ ■ ■	■ ■ ■ ■	■ ■ ■ ■	■ ■ ■ ■	■ ■ ■ ■				



VNG hand tools for blind rivet nuts / threaded bolts

	Blind rivet nuts							Blind rivet threaded bolts			
	M3	M4	M5	M6	M8	M10	M12	M4	M5	M6	M8
VNG 152	■ ■ ■	■ ■ ■	■ ■ ■	■ ■	■			■	■	■	■
VNG 255	optional ■ ■ ■	■ ■ ■	■ ■ ■	■ ■				■	■		
VNG 371			■ ■ ■	■ ■ ■	■ ■ ■	■ ■ ■			■	■	■
VNG 612		optional ■ ■ ■	■ ■ ■	■ ■ ■	■ ■ ■	■ ■ ■	■ ■		■	■	■

MULTI hand tools

	Blind rivet nuts							Blind rivet threaded bolts			
	M3	M4	M5	M6	M8	M10	M12	M4	M5	M6	M8
Multi 1	■ ■	■ ■	■ ■	■							
Multi 5	optional ■ ■	■ ■	■ ■	■ ■	■ ■	■					

VNG blind rivet tools (pneumatic-hydraulic)

	Blind rivet nuts							Blind rivet threaded bolts			
	M3	M4	M5	M6	M8	M10	M12	M4	M5	M6	M8
VNG 703	■ ■	■ ■ ■	■ ■ ■	■ ■ ■	■ ■ ■			■	■	■	
VNG 903		■ ■ ■	■ ■ ■	■ ■ ■	■ ■ ■	■ ■ ■	optional ■ ■ ■	■	■	■	■

VNG tool for folding blind rivet nuts (pneumatic-hydraulic)

	Blind rivet nuts						
	M3	M4	M5	M6	M8	M10	M12
VNG 753		optional ■	optional ■	■	■	optional ■	



HAND TOOLS



Manually operated blind rivet hand tools are indispensable even today for the processing of small quantities of blind rivet products.

On the following pages you will find the right variant for every application – from sturdy **one-hand riveter** for do-it-yourselfers or repair work through universal **MULTI tools for all types of blind rivet** through to the comfortable **special tool with integrated hydraulics**.



Hand Tools

BZ 2

Hand Tool for Blind Rivets
with opening spring



**Good ergonomics,
brilliant transformation**

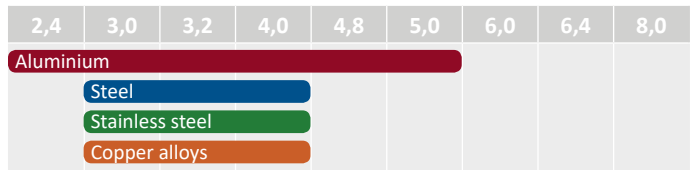

0,56 kg
 Blister
 8,00 mm
 including 4 nose pieces

Item no. 310.002.000.000

Spare Parts for BZ 2

No.	Spare part	Item no.
1A	BZ 2 nose piece 2,4 mm	311.002.000.024
1B	BZ 2 nose piece 3,0/3,2 mm	311.002.000.123
1C	BZ 2 nose piece 4,0 mm	311.002.000.124
1D	BZ 2 nose piece 4,8/5,0 mm	311.002.000.125
2	BZ 2 clamping sleeve	311.002.000.040
3	BZ 2 clamping jaws	311.002.000.132
4	BZ 2 guide sleeve	311.002.000.006
5	BZ 2 pressure spring	311.002.000.007
6	BZ 2 clamping screw	311.100.000.023
7	BZ 2 leg spring	311.002.000.101

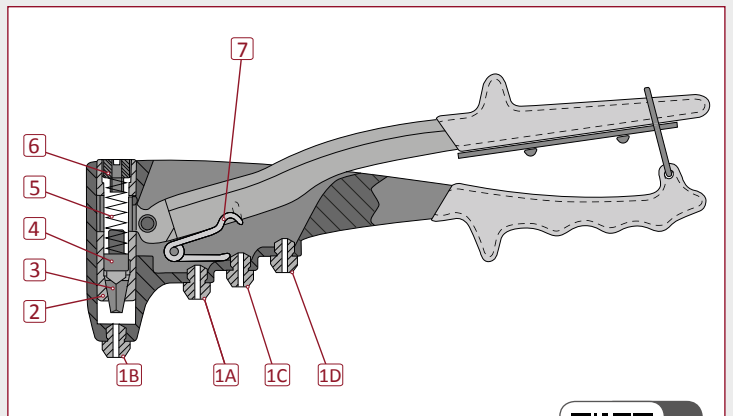

You can also use our interactive product viewer
for fast search for the correct spare part.



New compact assortment boxes
in sturdy plastic cases!

BZ 2 - Assortment boxes



BZ 2 ALFO® Aluminium/Steel

Assortment box made out of sturdy plastic with hand rivet tool BZ 2 including jaw wrench, additional clamping jaws, each 1 pc. drill 3,1 mm und 4,1 mm and **350 blind rivets** in the following dimensions:

100 x ALFO® blind rivet
aluminium/steel galvanised
3,0 x 6,0 dome head
grip range: 1,5 - 4,0 mm
item no.: 10.700.030.060

50 x ALFO® blind rivet
aluminium/steel galvanised
3,0 x 8,0 dome head
grip range: 3,0 - 6,0 mm
item no.: 10.700.030.080

50 x ALFO® blind rivet
aluminium/steel galvanised
3,0 x 10,0 dome head
grip range: 5,0 - 7,5 mm
item no.: 10.700.030.100

50 x ALFO® blind rivet
aluminium/steel galvanised
4,0 x 6,0 dome head
grip range: 1,0 - 3,5 mm
item no.: 10.700.040.060

50 x ALFO® Blind rivet
aluminium/steel galvanised
4,0 x 8,0 dome head
grip range: 3,0 - 5,5 mm
item no.: 10.700.040.080

50 x ALFO® Blind rivet
aluminium/steel galvanised
4,0 x 10,0 dome head
grip range: 5,0 - 7,0 mm
item no.: 10.700.040.100

Item no. 310.002.700.000



BZ 2 ALFO® Aluminium/Stainless steel

Assortment box made out of sturdy plastic with hand rivet tool BZ 2 including jaw wrench, additional clamping jaws, each 1 pc. drill 3,1 mm und 4,1 mm and **350 blind rivets** in the following dimensions:

100 x ALFO® blind rivet
aluminium/stainless steel
3,0 x 6,0 dome head
grip range: 1,5 - 4,0 mm
item no.: 10.702.030.060

50 x ALFO® blind rivet
aluminium/stainless steel
3,0 x 8,0 dome head
grip range: 3,0 - 6,0 mm
item no.: 10.702.030.080

50 x ALFO® blind rivet
aluminium/stainless steel
3,0 x 10,0 dome head
grip range: 5,0 - 7,5 mm
item no.: 10.702.030.100

50 x ALFO® blind rivet
aluminium/stainless steel
4,0 x 6,0 dome head
grip range: 1,0 - 3,5 mm
item no.: 10.702.040.060

50 x ALFO® blind rivet
aluminium/stainless steel
4,0 x 8,0 dome head
grip range: 3,0 - 5,5 mm
item no.: 10.702.040.080

50 x ALFO® blind rivet
aluminium/stainless steel
4,0 x 10,0 dome head
grip range: 5,0 - 7,0 mm
item no.: 10.702.040.100

Item no. 310.002.702.000



BZ 2 OPTO® Aluminium/Steel

Assortment box made out of sturdy plastic with hand rivet tool BZ 2 including jaw wrench, additional clamping jaws, each 1 pc. drill 3,3 mm, 4,1 mm and 4,9 mm and **350 blind rivets** in the following dimensions:

100 x OPTO® multigrip blind rivet
aluminium/steel
3,2 x 8,0 dome head
grip range: 0,8 - 4,8 mm
item no.: 10.600.032.080

50 x OPTO® multigrip blind rivet
aluminium/steel
3,2 x 11,0 dome head
grip range: 4,0 - 7,9 mm
item no.: 10.600.032.110

50 x OPTO® multigrip blind rivet
aluminium/steel
4,0 x 6,0 dome head
grip range: 0,5 - 3,0 mm
item no.: 10.600.040.060

50 x OPTO® multigrip blind rivet
aluminium/steel
4,0 x 9,5 dome head
grip range: 1,2 - 6,4 mm
item no.: 10.600.040.095

25 x OPTO® multigrip blind rivet
aluminium/steel
4,8 x 10,3 dome head
grip range: 1,5 - 6,0 mm
item no.: 10.600.048.103

25 x OPTO® multigrip blind rivet
aluminium/steel
4,8 x 15,1 dome head
grip range: 4,8 - 11,1 mm
item no.: 10.600.048.151

Item no. 310.002.600.000

BZ 44

Hand Tool for Blind Rivets
with opening spring



Classic tool - Sturdy and reliable



2,4	3,0	3,2	4,0	4,8	5,0	6,0	6,4	8,0
Aluminium								
Steel								
Stainless steel								
Copper alloys								

kg 0,63 kg **Blister** **HUB** 9,5 mm

including 4 nose pieces

Item no. 310.044.000.000

! **With retension mechanism for the rivet mandrel.**
The mandrel stays in the tool in all phases of the riveting process, so that the tool can easily be handled with one hand, while the other hand fixes the working piece.

Spare Parts for BZ 44

No.	Spare part	Item no.
1A	BZ 44 nose piece 2,4 mm	311.002.000.024
1B	BZ 44 nose piece 3,0/3,2 mm	311.002.000.123
1C	BZ 44 nose piece 4,0 mm	311.002.000.124
1D	BZ 44 nose piece 4,8/5,0 mm	311.002.000.125
2	BZ 44 clamping sleeve	311.044.000.003
3	BZ 44 clamping jaws	311.002.000.132
4	BZ 44 guide sleeve	311.044.000.005
5	BZ 44 pressure spring	311.044.000.006
6	BZ 44 clamping screw	311.044.000.007
7	BZ 44 leg spring	311.044.000.102

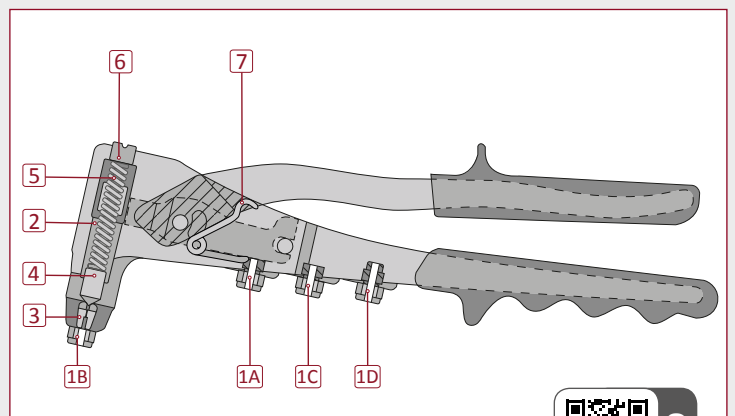

You can also use our interactive product viewer for fast search for the correct spare part.



New compact assortment boxes
in sturdy plastic cases!

BZ 44 Assortment boxes



BZ 44 ALFO® Aluminium/Steel

Assortment box made out of sturdy plastic with hand rivet tool BZ 44 including jaw wrench, additional clamping jaws, each 1 pc. drill 3,1 mm and 4,1 mm and **350 blind rivets** in the following dimensions:

100 x ALFO® blind rivet aluminium/steel galvanized
3,0 x 6,0 dome head
grip range: 1,5 - 4,0 mm
item no.: 10.700.030.060

50 x ALFO® blind rivet aluminium/steel galvanized
3,0 x 8,0 dome head
grip range: 3,0 - 6,0 mm
item no.: 10.700.030.080

50 x ALFO® blind rivet aluminium/steel galvanized
3,0 x 10,0 dome head
grip range: 5,0 - 7,5 mm
item no.: 10.700.030.100

50 x ALFO® blind rivet aluminium/steel galvanized
4,0 x 6,0 dome head
grip range: 1,0 - 3,5 mm
item no.: 10.700.040.060

50 x ALFO® blind rivet aluminium/steel galvanized
4,0 x 8,0 dome head
grip range: 3,0 - 5,5 mm
item no.: 10.700.040.080

50 x ALFO® blind rivet aluminium/steel galvanized
4,0 x 10,0 dome head
grip range: 5,0 - 7,0 mm
item no.: 10.700.040.100

Item no. 310.044.700.000



BZ 44 Lightweight Construction

Assortment box made out of sturdy plastic with hand rivet tool BZ 44 including jaw wrench, additional clamping jaws, each 1 pc. drill 3,3 mm, 4,1 mm and 4,9 mm and **260 blind rivets** in the following dimensions:

100 x OPTO® multigrip blind rivet aluminium/aluminium
3,2 x 8,0 dome head
grip range: 1,0 - 4,7 mm
item no.: 10.601.032.080

50 x OPTO® multigrip blind rivet aluminium/aluminium
3,2 x 11,0 dome head
grip range: 4,0 - 7,5 mm
item no.: 10.601.032.110

50 x OPTO® multigrip blind rivet aluminium/aluminium
4,0 x 9,5 dome head
grip range: 1,5 - 6,4 mm
item no.: 10.601.040.095

25 x OPTO® multigrip blind rivet aluminium/aluminium
4,8 x 10,3 dome head
grip range: 1,6 - 6,3 mm
item no.: 10.601.048.103

25 x folding blind rivet ALU/ALU
4,0 x 18,8 dome head
grip range: 3,0 - 7,0mm
item no.: 10.716.040.188

10 x folding blind rivet ALU/ALU
4,8 x 20,5 dome head
grip range: 3,0 - 9,0 mm
item no.: 10.716.048.205

Item no. 310.044.601.716



BZ 44 CERTO® Aluminium/Steel

Assortment box made out of sturdy plastic with hand rivet tool BZ 44 including jaw wrench, additional clamping jaws, each 1 pc. drill 3,3 mm and 4,1 mm and **300 blind rivets** in the following dimensions:

50 x CERTO® sealed blind rivet aluminium/steel
3,2 x 6,5 dome head
grip range: 0,5 - 2,0 mm
item no.: 10.900.032.065

50 x CERTO® sealed blind rivet aluminium/steel
3,2 x 8,0 dome head
grip range: 1,5 - 3,5 mm
item no.: 10.900.032.080

50 x CERTO® sealed blind rivet aluminium/steel
3,2 x 9,5 dome head
grip range: 3,0 - 5,0 mm
item no.: 10.900.032.095

50 x CERTO® sealed blind rivet aluminium/steel
4,0 x 8,0 dome head
grip range: 0,5 - 3,5 mm
item no.: 10.900.040.080

50 x CERTO® sealed blind rivet aluminium/steel
4,0 x 9,5 dome head
grip range: 3,0 - 5,0 mm
item no.: 10.900.040.095

50 x CERTO® Dicht-Blindniet ALU/STAHL
4,0 x 11,0 Flachkopf
Klemmbereich: 4,5 - 6,5 mm
Art. No.: 10.900.040.110

Item no. 310.044.900.000

BZ 6

Hand Tool for Blind Rivets

including various assortments | 360° rotating head

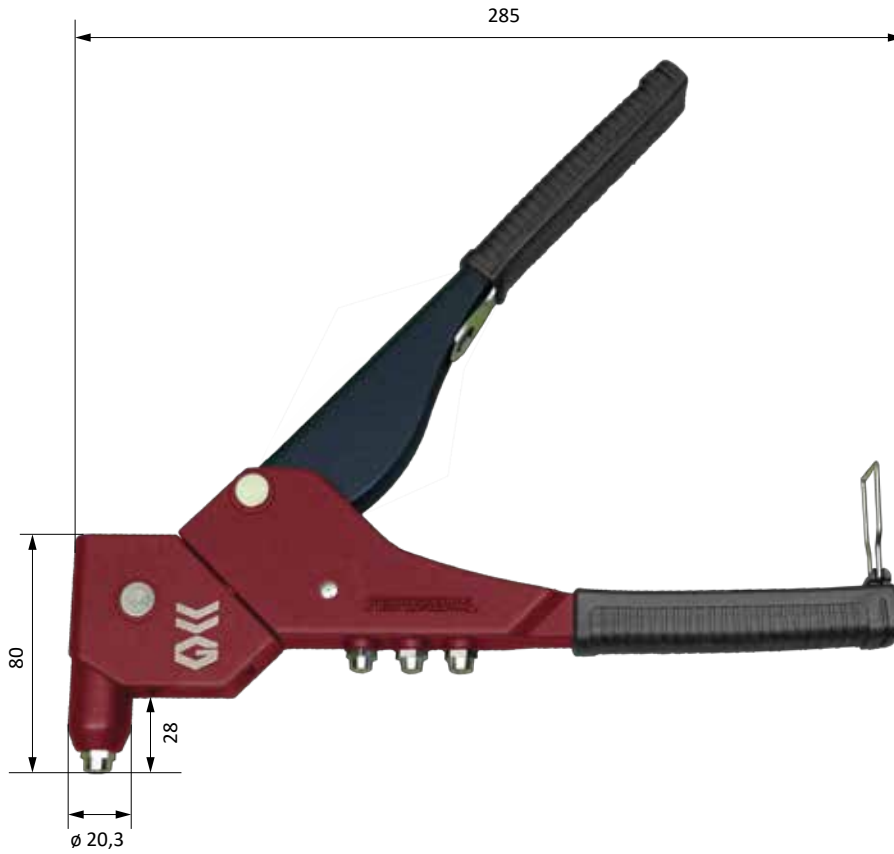

Possible positions to work:



	2,4	3,0	3,2	4,0	4,8	5,0	6,0	6,4	8,0
Aluminium	█								
Steel	█								
Stainless steel	█								
Copper alloys	█								

kg 0,9 kg

Plastic case

325 x 250 x 50 mm **!** continuous pivotable about 360°

Available in the assortment boxes on the right

Spare Parts for BZ 6

No.	Spare part	Item no.
1A	BZ 6 nose piece 2,4 mm	311.006.000.024
1B	BZ 6 nose piece 3,0/3,2 mm	311.006.000.123
1C	BZ 6 nose piece 4,0 mm	311.006.000.124
1D	BZ 6 nose piece 4,8/5,0 mm	311.006.000.125
2	BZ 6 clamping sleeve	311.006.000.040
3	BZ 6 clamping jaws	311.006.000.132
4	BZ 6 guide sleeve	311.006.000.006
5	BZ 6 pressure spring	311.006.000.007
6	BZ 6 locking screw	311.006.000.008

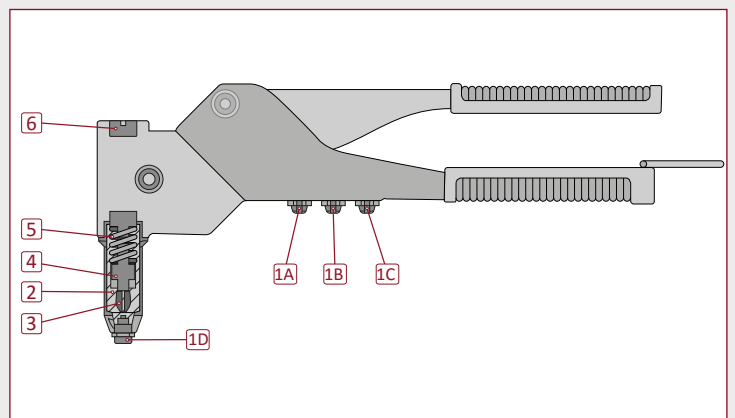

New compact assortment boxes
in sturdy plastic cases!

BZ 6 Assortment boxes



BZ 6 OPTO® Aluminium/Steel

Assortment box made out of sturdy plastic with hand rivet tool BZ 6 including jaw wrench and **350 blind rivets** in the following dimensions:

100 x OPTO® multigrip blind rivet **aluminium/steel**
3,2 x 8,0 dome head
grip range: 0,8 - 4,8 mm
item no.: 10.600.032.080

100 x OPTO® multigrip blind rivet **aluminium/steel**
3,2 x 11,0 dome head
grip range: 4,0 - 7,9 mm
item no.: 10.600.032.110

50 x OPTO® multigrip blind rivet **aluminium/steel**
4,0 x 6,0 dome head
grip range: 0,5 - 3,0 mm
item no.: 10.600.040.060

50 x OPTO® multigrip blind rivet **aluminium/steel**
4,0 x 9,5 dome head
grip range: 1,2 - 6,4 mm
item no.: 10.600.040.095

25 x OPTO® multigrip blind rivet **aluminium/steel**
4,8 x 10,3 dome head
grip range: 1,5 - 6,0 mm
item no.: 10.600.048.103

25 x OPTO® multigrip blind rivet **aluminium/steel**
4,8 x 15,1 dome head
grip range: 4,8 - 11,1 mm
item no.: 10.600.048.151

Item no. 310.006.600.000



BZ 6 OPTO® Aluminium/Stainless steel FACADE

Assortment box made out of sturdy plastic with hand rivet tool BZ 6 including jaw wrench and **170 blind rivets** in the following dimensions:

50 x OPTO® multigrip blind rivet **aluminium/stainless steel**
3,2 x 8,0 large dome head K9,5
grip range: 0,5 - 5,0 mm
item no.: 10.632.032.080

50 x OPTO® multigrip blind rivet **aluminium/stainless steel**
3,2 x 11,0 large dome head K9,5
grip range: 4,0 - 7,9 mm
item no.: 10.632.032.110

25 x OPTO® multigrip blind rivet **aluminium/stainless steel**
4,0 x 9,5 large dome head K12
grip range: 1,2 - 6,4 mm
item no.: 10.652.040.095

25 x OPTO® multigrip blind rivet **aluminium/stainless steel**
4,0 x 12,7 large dome head K12
grip range: 4,0 - 9,5 mm
item no.: 10.652.040.127

10 x OPTO® multigrip blind rivet **aluminium/stainless steel**
4,8 x 10,3 large dome head K16
grip range: 1,6 - 6,4 mm
item no.: 10.672.048.103

10 x OPTO® multigrip blind rivet **aluminium/stainless steel**
4,8 x 16,9 large dome head K16
grip range: 6,4 - 12,7 mm
item no.: 10.672.048.169

Item no. 310.006.632.000



BZ 6 OPTO® Stainless steel

Assortment box made out of sturdy plastic with hand rivet tool BZ 6 including jaw wrench and **350 blind rivets** in the following dimensions:

100 x OPTO® multigrip blind rivet **stainless steel/stainless steel**
3,2 x 8,0 dome head
grip range: 1,0 - 4,0 mm
item no.: 10.618.032.080

50 x OPTO® multigrip blind rivet **stainless steel/stainless steel**
4,0 x 10,0 dome head
grip range: 1,0 - 4,5 mm
item no.: 10.618.040.100

50 x CERTO® sealed blind rivet **stainless steel/stainless steel**
3,2 x 8,0 dome head
grip range: 1,0 - 3,5 mm
item no.: 10.908.032.080

50 x CERTO® sealed blind rivet **stainless steel/stainless steel**
3,2 x 9,5 dome head
grip range: 2,5 - 5,0 mm
item no.: 10.908.032.095

50 x CERTO® sealed blind rivet **stainless steel/stainless steel**
4,0 x 8,0 dome head
grip range: 1,0 - 3,0 mm
item no.: 10.908.040.080

50 x CERTO® sealed blind rivet **stainless steel/stainless steel**
4,0 x 9,5 dome head
grip range: 2,5 - 4,5 mm
item no.: 10.908.040.095

Item no. 310.006.618.908

BZ 70 / 72

Lever Tool for Blind Rivets



BZ 70

2,4	3,0	3,2	4,0	4,8	5,0	6,0	6,4	8,0
Aluminium								
Steel								
Stainless steel								
Copper alloys								

1,5 kg	Case	3,2 mm
14,5 mm	incl. 4 nose pieces	Special nose pieces on request

Item no. 310.070.000.000



BZ 72

2,4	3,0	3,2	4,0	4,8	5,0	6,0	6,4	8,0
Aluminium								
Steel								
Stainless steel								
Copper alloys								

1,65 kg	Case	4,0 mm
14,5 mm	incl. 4 nose pieces	Special nose pieces on request

Item no. 310.072.000.000

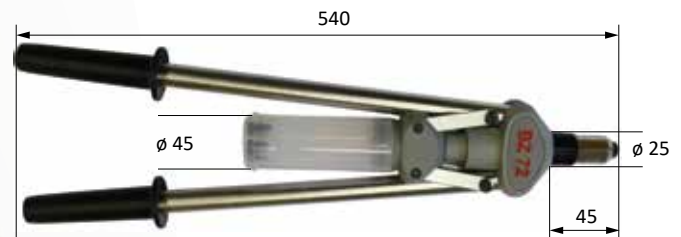

Replacement nose pieces in locked box (integrated) in the mandrel container.



Lever tool BZ 70 in impact-resistant plastic case.

Spare parte für BZ 70/72

No.	Spare part	Item no.
1A	BZ 70 nose piece 3,0/3,2 mm	311.070.000.001
1B/1A	BZ 70/72 nose piece 4,0 mm	311.070.000.002
1C/1B	BZ 70/72 nose piece 4,8/5,0 mm	311.070.000.003
1D/1C	BZ 70/72 nose piece 6,0 mm	311.070.000.004
1D	BZ 72 nose piece 6,4 mm	311.072.000.001
2	BZ 70/72 clamping sleeve	311.070.000.008
3	BZ 70/72 clamping jaws	311.070.000.006
4	BZ 70/72 guide sleeve	311.070.000.009
5	BZ 70/72 pressure spring	311.070.000.010
6	BZ 70/72 lock nut	311.070.000.011
7	BZ 70/72 front sleeve	311.070.000.005
8	BZ 70/72 mandrel collector	311.070.000.007
Facade nosepiece 5,0 mm Head 11,0 mm		321.120.000.511
Facade nosepiece 5,0 mm Head 14,0 mm		321.120.000.514
Facade nosepiece 5,0 mm Head 16,0 mm		321.120.000.516

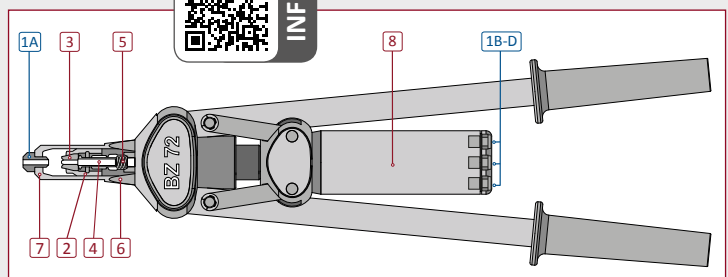
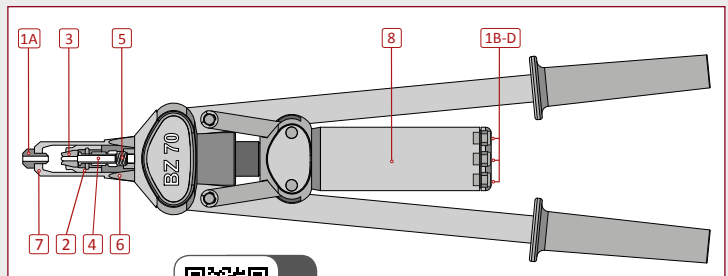

BZ 58

Lazy Tong Blind Rivet Tool



BZ 58

2,4	3,0	3,2	4,0	4,8	5,0	6,0	6,4	8,0
Aluminium								
Steel								
Stainless steel								
Copper alloys								
2,0 kg	Carton	3,8 mm						
11 mm	incl. 5 nose pieces	Special nose pieces on request						
Item no. 310.058.000.000								

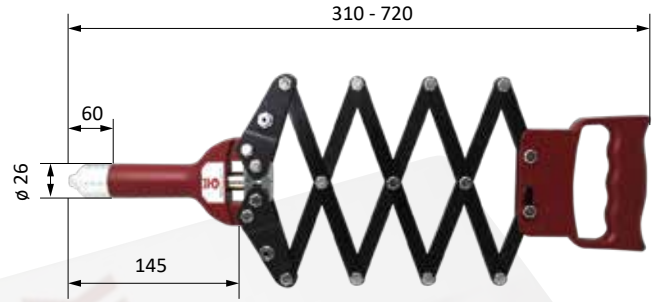

Replaceable nosepieces screwed into the tool.



Spare Parts for BZ 58

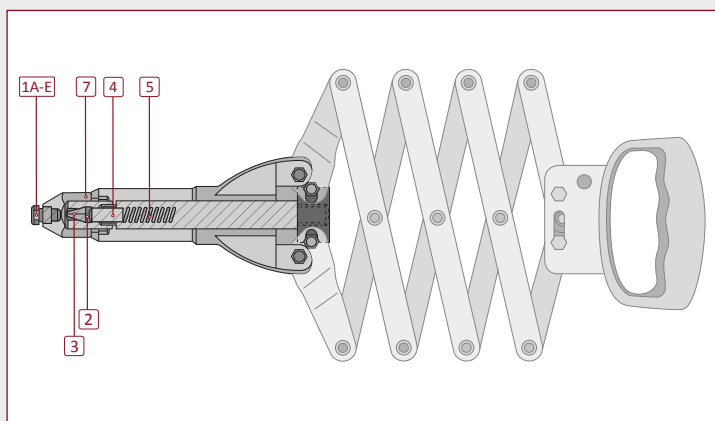

No.	Spare part	Item no.
1A	BZ 58 nose piece 3,0/3,2 mm	311.100.000.123
1B	BZ 58 nose piece 4,0 mm	311.100.000.124
1C	BZ 58 nose piece 4,8/5,0 mm	311.100.000.125
1D	BZ 58 nose piece 6,0 mm	311.500.000.126
1E	BZ 58 nose piece 6,4 mm	311.500.000.127
2	BZ 58 clamping sleeve	311.500.000.004
3	BZ 58 clamping jaws	311.500.000.005
4	BZ 58 guide sleeve	311.500.000.006
5	BZ 58 pressure spring	311.500.000.007
7	BZ 58 front sleeve	311.058.002.006

You can also use our interactive product viewer for fast search for the correct spare part.



VNG 255

Hand Tool for Blind Rivet Nuts and Blind Rivet Bolts
with different assortments | 360° rotating head

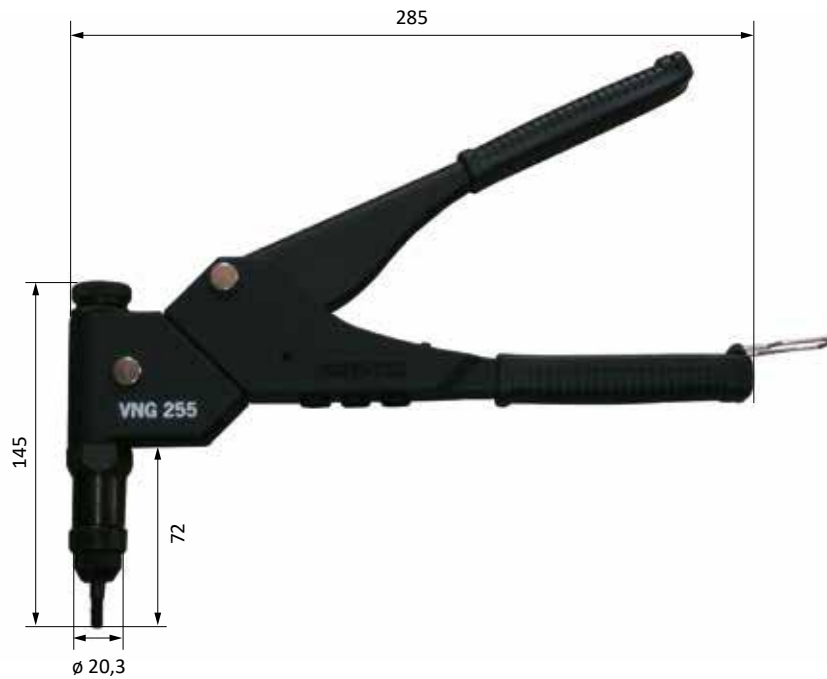

Possible positions to work:

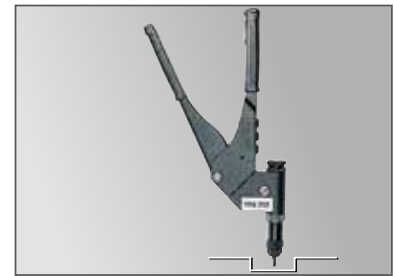

M3	M4	M5	M6	M8	M10	M12
optional Aluminium						
optional Steel						
optional Stainless steel						

Steel						
-------	--	--	--	--	--	--

- 0,9 kg
- Plastic case
- 325 x 250 x 50 mm
- continuous pivotable about 360°

Available in the assortment boxes on the right

Spare Parts for VNG 255

No.	Spare part	Item no.
1A	VNG 255 mandrel M3	311.800.000.030
1B	VNG 255 mandrel M4	311.800.000.040
1C	VNG 255 mandrel M5	311.800.000.050
1D	VNG 255 mandrel M6	311.800.000.060
2A	VNG 255 nose piece M3	311.800.000.203
2B	VNG 255 nose piece M4	311.800.000.204
2C	VNG 255 nose piece M5	311.800.000.205
2D	VNG 255 nose piece M6	311.800.000.206
4	VNG 255 lock nut M18x1	321.801.000.074
5	VNG 255 lock nut M8x1	321.801.000.075
6	VNG 255 front sleeve	311.255.000.020
3A*	VNG 255 threaded sleeve M4	321.800.001.004
3B*	VNG 255 threaded sleeve M5	321.800.001.005

* not illustrated

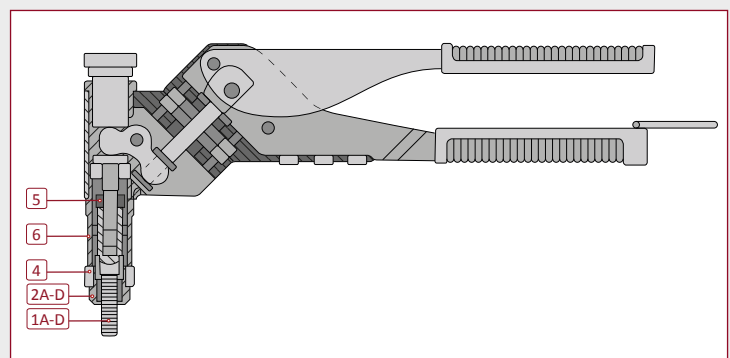

You can also use our interactive product viewer for fast search for the correct spare part.



A bestseller - sold 10.000 times!



VNG 255 CLASSIC

Assortment box made out of sturdy plastic with hand rivet tool VNG 255 for blind rivet nuts and blind rivet bolts including each with 1 piece conversation kit for blind rivet nuts M4/M5/M6, each with 1 piece threaded sleeve for blind rivet bolts M4/M5, each with 1 piece jaw wrench AF 22/AF 24, 1 piece hex head wrench AF 6 and **150 blind rivet nuts and bolts** in the following dimensions:

25 x blind rivet nuts UNIVERSAL steel M4 small countersunk head grip range: 0,5 - 3,0 mm item no.: 10.870.400.000	25 x blind rivet nuts UNIVERSAL steel M5 small countersunk head grip range: 0,5 - 3,0 mm item no.: 10.870.500.000	50 x blind rivet nuts UNIVERSAL steel M6 small countersunk head grip range: 0,5 - 3,0 mm item no.: 10.870.600.000
25 x blind rivet bolts RIFBOLT® steel M4 dome head grip range: 0,3 - 2,0 mm item no.: 10.880.042.010	25 x blind rivet bolts RIFBOLT® steel M5 dome head grip range: 0,5 - 2,0 mm item no.: 10.880.052.010	

Item no. 310.255.000.000



VNG 255 BASIC

Assortment box made out of sturdy plastic with hand rivet tool VNG 255 for blind rivet nuts and blind rivet bolts including each with 1 piece conversation kit for blind rivet nuts M4/M5/M6, each with 1 piece threaded sleeve for blind rivet bolts M4/M5, each with 1 piece jaw wrench AF 22/AF 24, 1 piece hex head wrench AF 6 and **450 blind rivet nuts** in the following dimensions:

100 x blind rivet nuts SFM 4-25 R steel knurled M4 dome head grip range: 0,5 - 2,5 mm item no.: 10.842.040.250	50 x blind rivet nuts SFM-5-30 R steel knurled M5 dome head grip range: 0,5 - 3,0 mm item no.: 10.842.050.300	50 x blind rivet nuts SFM-5-50 R steel knurled M5 dome head grip range: 2,5 - 5,0 mm item no.: 10.842.050.500
100 x blind rivet nuts UNIVERSAL steel knurled M4 small countersunk head grip range: 0,5 - 3,0 mm item no.: 10.871.400.000	100 x blind rivet nuts UNIVERSAL steel knurled M5 small countersunk head grip range: 0,5 - 3,0 mm item no.: 10.871.500.000	50 x blind rivet nuts UNIVERSAL steel knurled M6 small countersunk head grip range: 0,5 - 3,0 mm item no.: 10.871.600.000

Item no. 310.255.842.871



VNG 255 OPTO®

Assortment box made out of sturdy plastic with hand rivet tool VNG 255 for blind rivet nuts and blind rivet bolts including each with 1 piece conversation kit for blind rivet nuts M4/M5/M6, each with 1 piece threaded sleeve for blind rivet bolts M4/M5, each with 1 piece jaw wrench AF 22/AF 24, 1 piece hex head wrench AF 6 and **250 OPTO® multigrip blind rivet nuts** in the following dimensions:

50 x blind rivet nuts OPTO® AFM4-60 aluminium M4 dome head grip range: 0,5 - 6,0 mm item no.: 10.894.040.600	50 x blind rivet nuts OPTO® AFM5-60 aluminium M5 dome head Klemmbereich: 0,5 - 6,0 mm Art. Nr.: 10.894.050.600	25 x blind rivet nuts OPTO® AFM6-60 aluminium M6 dome head Klemmbereich: 0,5 - 6,0 mm Art. Nr.: 10.894.060.600
50 x blind rivet nuts OPTO® ASM4-60 aluminium M4 countersunk head grip range: 1,5 - 6,0 mm item no.: 10.894.400.600	50 x blind rivet nuts OPTO® ASM5-60 aluminium M5 countersunk head grip range: 1,5 - 6,0 mm item no.: 10.894.500.600	25 x blind rivet nuts OPTO® ASM6-60 aluminium M6 countersunk head grip range: 1,5 - 6,0 mm item no.: 10.894.600.600

Item no. 310.255.894.000

VNG 152

Hand Tool for Blind Rivet Nuts and Blind Rivet Bolts
with hydraulic assistance

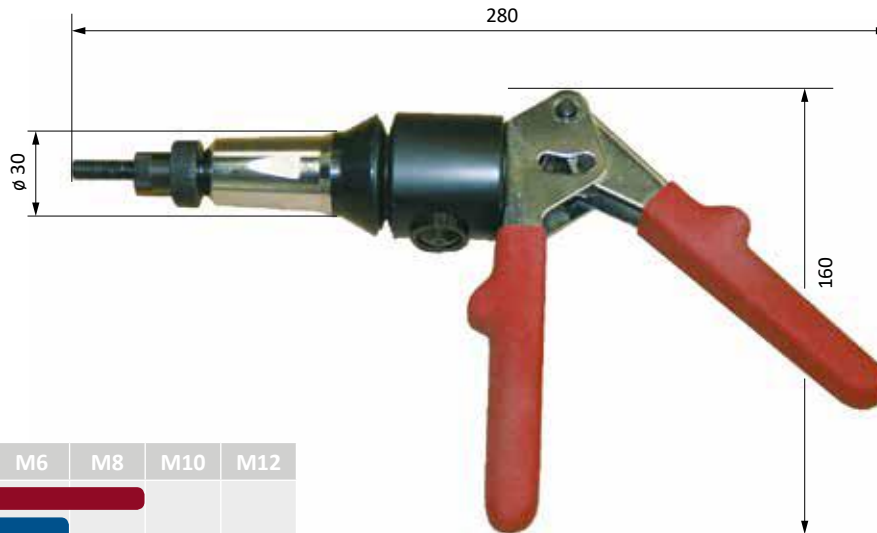

M3	M4	M5	M6	M8	M10	M12
Aluminium						
Steel						
Stainless steel						



Steel		
-------	--	--

0,6 kg  with hydraulic component

Plastic case  290 x 195 x 54 mm

1 conversion kit each for M3, M4, M5, M6 and M8 for blind rivet nuts, M4, M5, M6 and M8 for RIFBOLT® bolts

Item no. 310.152.000.000



Easy working thanks for hydraulic-assisted short strokes.

Impact-resistant plastic case.

Spare Parts for VNG 152

No.	Spare part	Item no.
2	VNG 152 housing cover	311.151.000.009
5	VNG 152 pressure spring	311.151.000.010
6	VNG 152 front sleeve	311.151.000.001
7A	VNG 152 nose piece BNM M3	311.151.002.003
7B	VNG 152 nose piece BNM M4	311.151.002.004
7C	VNG 152 nose piece BNM M5	311.151.002.005
7D	VNG 152 nose piece BNM M6	311.151.002.006
7E	VNG 152 nose piece BNM M8	311.151.002.008
8A	VNG 152 mandrel M3	311.151.003.003
8B	VNG 152 mandrel M4	311.151.003.004
8C	VNG 152 mandrel M5	311.151.003.005
8D	VNG 152 mandrel M6	311.151.003.006
8E	VNG 152 mandrel M8	311.151.003.008
9	VNG 152 adapter for nose piece	311.151.000.008
10	VNG 152 adapter for mandrel	311.151.000.007
11A	VNG 152 nose piece Rifbolt M4	311.151.007.004
11B	VNG 152 nose piece Rifbolt M5	311.151.007.005
11C	VNG 152 nose piece Rifbolt M6	311.151.007.006
11D	VNG 152 nose piece Rifbolt M8	311.151.007.008
12A	VNG 152 threaded sleeve Rifbolt	311.151.004.004
12B	VNG 152 threaded sleeve Rifbolt	311.151.004.005
12C	VNG 152 threaded sleeve Rifbolt	311.151.004.006
12D	VNG 152 threaded sleeve Rifbolt	311.151.004.008

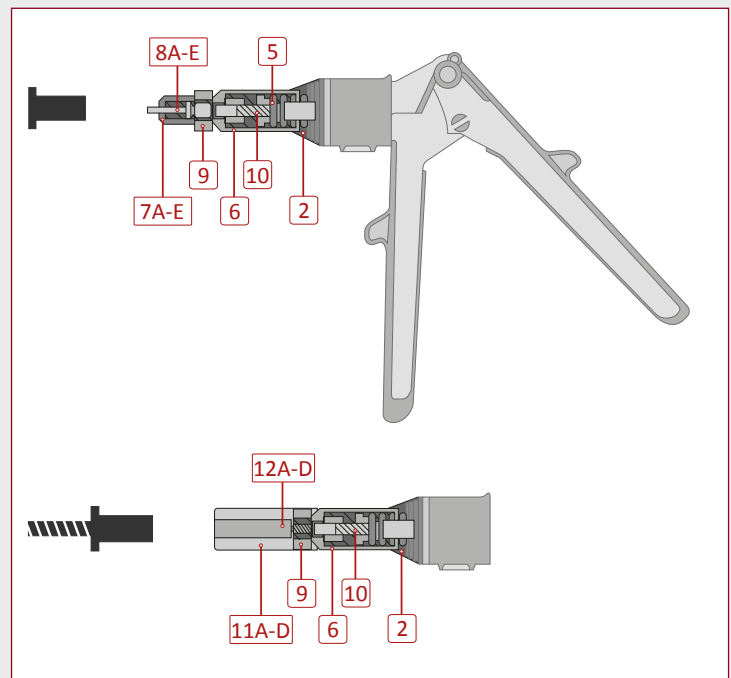

You can also use our interactive product viewer for fast search for the correct spare part.



VNG 612

Hand Tool for Blind Rivet Nuts and Blind Rivet Bolts



M3	M4	M5	M6	M8	M10	M12
	optional	Aluminium				
	optional	Steel				
	optional	Stainless steel				

			Steel			
--	--	--	-------	--	--	--

- 1,1 kg
- Case in aluminium optics 325 x 250 x 50 mm
- 1 conversion kit each for M5 - M12 blind rivet nuts,
1 threaded sleeve each for RIFBOLT® M5 - M8 blind rivet bolts

Item no. 310.612.000.000



Carrying case in aluminium finish with foam inlay.



Spare Parts for VNG 612

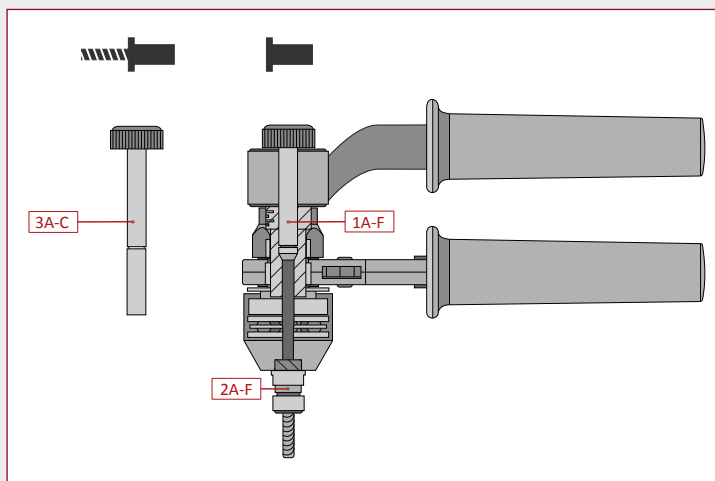

No.	Spare part	Item no.
1A	VNG 612 mandrel M4	311.612.000.040
1B	VNG 612 mandrel M5	311.612.000.050
1C	VNG 612 mandrel M6	311.612.000.060
1D	VNG 612 mandrel M8	311.612.000.080
1E	VNG 612 mandrel M10	311.612.000.100
1F	VNG 612 mandrel M12	311.612.000.120
2A	VNG 612 nose piece M4	311.612.000.304
2B	VNG 612 nose piece M5	311.612.000.305
2C	VNG 612 nose piece M6	311.612.000.306
2D	VNG 612 nose piece M8	311.612.000.308
2E	VNG 612 nose piece M10	311.612.000.310
2F	VNG 612 nose piece M12	311.612.000.312
3A	VNG 612 threaded sleeve M5	311.612.000.205
3B	VNG 612 threaded sleeve M6	311.612.000.206
3C	VNG 612 threaded sleeve M8	311.612.000.208

You can also use our interactive product viewer for fast search for the correct spare part.



VNG 371

Lever Tool for Blind Rivet Nuts and Blind Rivet Bolts

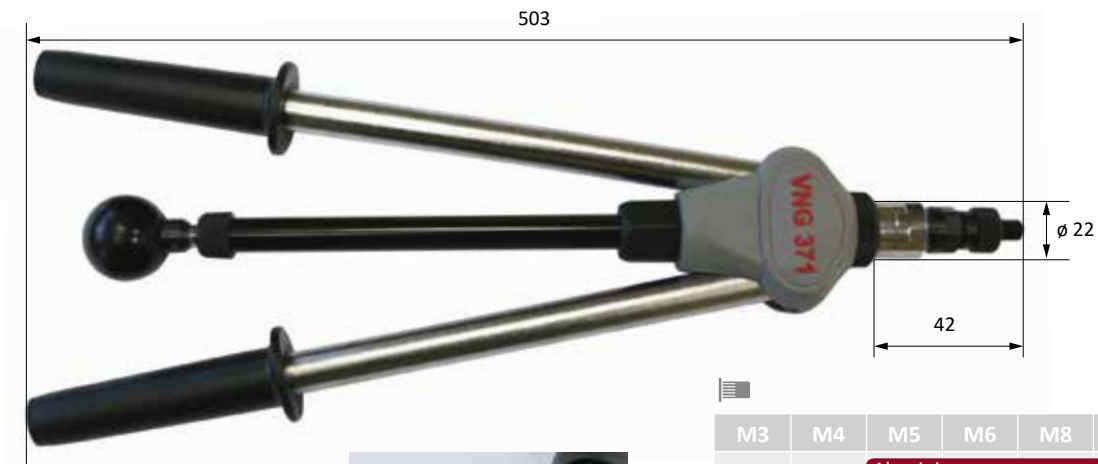

Impact-resistant plastic case.



Quick change system for the mandrel.

M3	M4	M5	M6	M8	M10	M12
		Aluminium				
		Steel				
		Stainless steel				

		Steel				
--	--	-------	--	--	--	--

1,2 kg

Plastic case

595 x 270 x 60 mm

- each with 1 piece conversation kit for blind rivet nuts M5, M6, M8, M10
- each with 1 piece threaded sleeve for blind rivet bolts M5, M6, M8

Item no. 310.371.000.000

Spare Parts for VNG 371

No.	Spare part	Item no.
1A	VNG 371 mandrel M5	311.371.000.005
1B	VNG 371 mandrel M6	311.371.000.006
1C	VNG 371 mandrel M8	311.371.000.007
1D	VNG 371 mandrel M10	311.371.000.008
2A	VNG 371 nose piece M5	311.371.000.001
2B	VNG 371 nose piece M6	311.371.000.002
2C	VNG 371 nose piece M8	311.371.000.003
2D	VNG 371 nose piece M10	311.371.000.004
3	VNG 371 lock nut nose piece	311.371.000.012
4	VNG 371 stroke adjusting cap	311.371.000.013
5	VNG 371 plastic knurled nut	311.371.000.015
6	VNG 371 o-ring	311.371.000.014
7	VNG 371 pressure spring	311.371.000.016
8	VNG 371 housing tube	311.371.000.017
9	VNG 371 connection sleeve	311.371.000.025
13	VNG 371 feed rod	311.371.000.030
17	VNG 371 stranded rod	311.371.000.020
18A	VNG 371 threaded sleeve M5	311.371.000.009
18B	VNG 371 threaded sleeve M6	311.371.000.010
18C	VNG 371 threaded sleeve M8	311.371.000.011

Spare part	Item no.
Mandrel M6 Folding blind rivet nuts	311.371.000.040
Mandrel M8 Folding blind rivet nuts	311.371.000.041

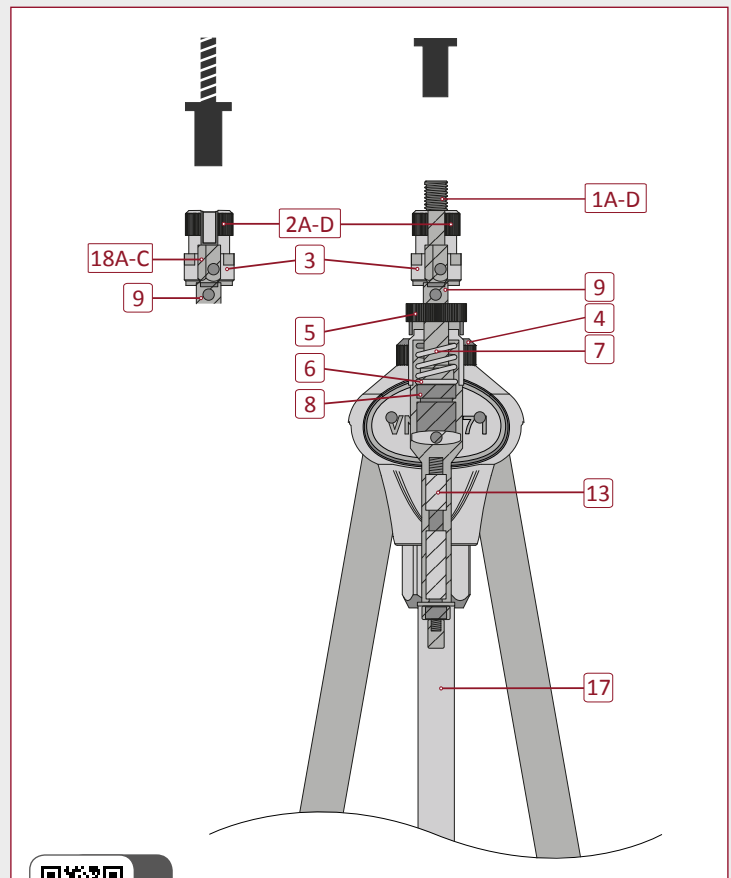

You can also use our interactive product viewer for fast search for the correct spare part.

MULTI 1

Hand Tool for Blind Rivets, Blind Rivet Nuts and Blind Rivet Bolts
360° rotating head

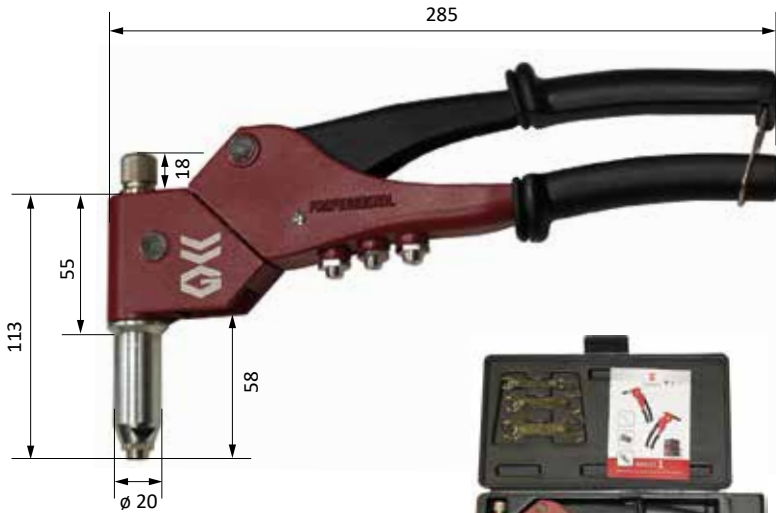

Impact-resistant plastic case.



2,4	3,0	3,2	4,0	4,8	5,0	6,0
Aluminium						
Steel						
Stainless steel						
Copper alloys						



M3	M4	M5	M6	M8	M10	M12
Aluminium						
Steel						



Steel						
-------	--	--	--	--	--	--

0,56 kg

! continuous pivotable about 360°

Plastic case

360 x 185 x 50 mm

- each with 1 nose piece for blind rivets 2,4; 3,0/3,2mm; 4,0 mm; 4,8/5,0mm
- each with 1 piece conversation kit for blind rivet nuts M3-M6
- each with 1 piece threaded sleeve for blind rivet bolts M4, M5

Item no. 310.100.000.000

Spare Parts for Multi 1

No.	Spare part	Item no.
1A	MULTI 1 nose piece 2,4 mm	311.100.000.240
1B	MULTI 1 nose piece 3,0/3,2 mm	311.100.000.123
1C	MULTI 1 nose piece 4,0mm	311.100.000.124
1D	MULTI 1 nose piece 4,8/5,0 mm	311.100.000.125
2	MULTI 1 clamping sleeve	311.100.000.025
3	MULTI 1 clamping jaws	311.100.000.026
4	MULTI 1 guide sleeve	311.100.000.021
5	MULTI 1 pressure spring	311.100.000.022
6	MULTI 1 clamping screw	311.100.000.023
7	MULTI 1 front sleeve blind rivet	311.100.000.019
8A	MULTI 1 mandrel M3	311.100.003.003
8B	MULTI 1 mandrel M4	311.100.003.004
8C	MULTI 1 mandrel M5	311.100.003.005
8D	MULTI 1 mandrel M6	311.100.003.006
9A	MULTI 1 nose piece M3	311.100.002.003
9B	MULTI 1 nose piece M4	311.100.002.004
9C	MULTI 1 nose piece M5	311.100.002.005
9D	MULTI 1 nose piece M6	311.100.002.006
10A	MULTI 1 threaded sleeve M4	311.100.004.004
10B	MULTI 1 threaded sleeve M5	311.100.004.005
10C	MULTI 1 threaded sleeve M6	311.100.004.006
11	MULTI 1 front sleeve blind rivet nut	311.100.000.119

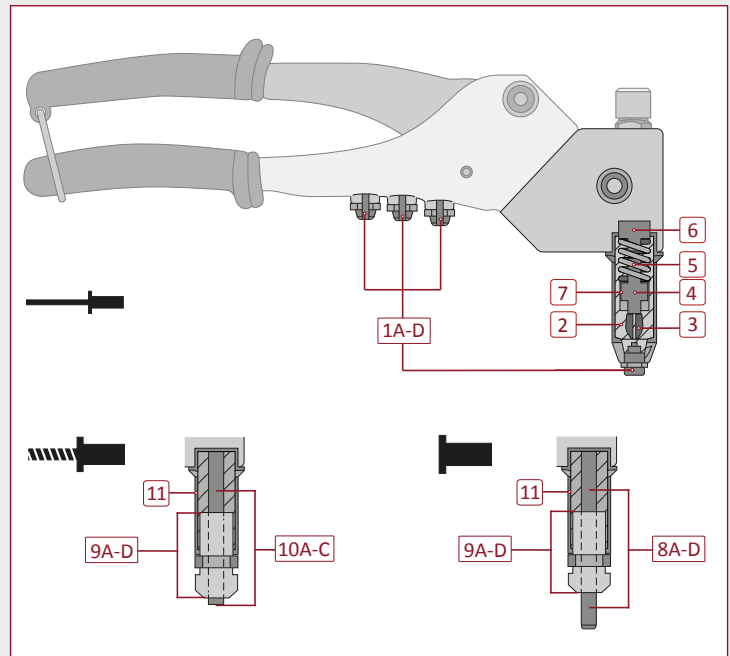

MULTI 1

You can also use our interactive product viewer for fast search for the correct spare part.



MULTI 5

Lever Tool for Blind Rivets, Blind Rivet Nuts and Blind Rivet Bolts
fold-away arms

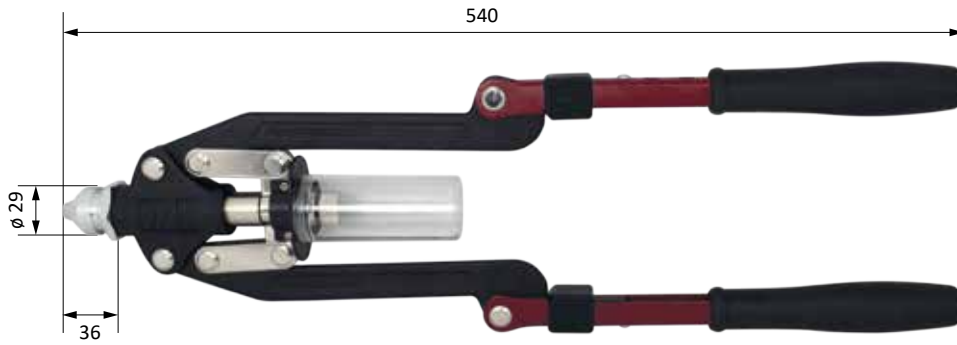

MULTI 5 with folded-in arms in impact-resistant plastic case.

M3	M4	M5	M6	M8	M10	M12
Aluminium						
Steel						

- 1,9 kg
- fold-away arms
- Plastic case
- 385 x 240 x 55 mm

Item no. 310.500.000.000

2,4	3,0	3,2	4,0	4,8	5,0	6,0	6,4
Aluminium							
Steel							
Stainless steel							
Copper alloys							

- each with 1 nose piece for blind rivets 3,0/3,2mm; 4,0mm; 4,8/5,0mm; 6,0mm; 6,4mm
- each with 1 piece conversation kit for blind rivet nuts M4 M5, M6, M8 and M10
- each with 1 piece threaded sleeve for blind rivet bolts M4, M5, M6 and M8



Spare Parts for Multi 5

No.	Spare part	Item no.
1A	MULTI 5 nose piece 3,0/3,2mm	311.100.000.123
1B	MULTI 5 nose piece 4,0mm	311.100.000.124
1C	MULTI 5 nose piece 4,8/5,0mm	311.100.000.125
1D	MULTI 5 nose piece 6,0mm	311.500.000.126
1E	MULTI 5 nose piece 6,4mm	311.500.000.127
2	MULTI 5 clamping sleeve	311.500.000.004
3	MULTI 5 clamping jaws	311.500.000.005
4	MULTI 5 guide sleeve	311.500.000.006
5	MULTI 5 pressure spring	311.500.000.007
6	MULTI 5 clamping screw	311.500.000.008
7	MULTI 5 front sleeve blind rivet	311.500.000.003
8A	MULTI 5 mandrel M4	311.100.003.004
8B	MULTI 5 mandrel M5	311.100.003.005
8C	MULTI 5 mandrel M6	311.100.003.006
8D	MULTI 5 mandrel M8	311.500.003.008
8E	MULTI 5 mandrel M10	311.500.003.010
9A	MULTI 5 nose piece M4	311.100.002.004
9B	MULTI 5 nose piece M5	311.100.002.005
9C	MULTI 5 nose piece M6	311.100.002.006
9D	MULTI 5 nose piece M8	311.500.002.008
9E	MULTI 5 nose piece M10	311.500.002.010

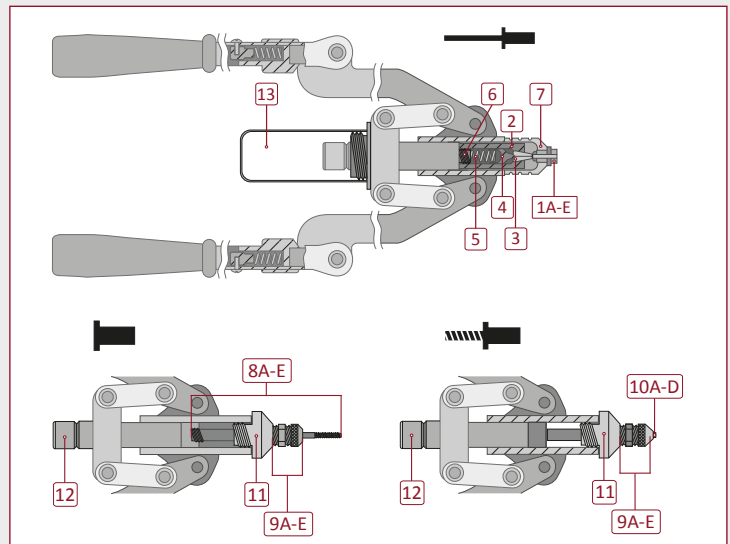

No.	Spare part	Item no.
10A	MULTI 5 threaded sleeve M4	311.100.004.004
10B	MULTI 5 threaded sleeve M5	311.100.004.005
10C	MULTI 5 threaded sleeve M6	311.100.004.006
10D	MULTI 5 threaded sleeve M8	311.500.004.008
11	Multi 5 front sleeve	311.500.000.025
12	Multi 5 feed rod	311.500.000.009
13	MULTI 5 mandrel collector	311.500.000.010



You can also use our interactive product viewer for fast search for the correct spare part.

THE BIG MULTI 5-ASSORTMENT

Indispensable
in each workshop



1 x MULTI 5
225 x blind rivets
825 x blind rivet nuts
375 x blind rivet bolts

OPTO® multigrip blind rivet
aluminium/Steel
3,2 x 8 dome head
grip range: 0,8 - 4,8 mm
item no.: 10.600.032.080

RIFBOLT® blind rivet bolt
steel
M4 dome head
grip range: 0,3 - 2,0 mm
item no.: 10.880.042.010

OPTO® multigrip blind rivet
nut AFM 4-60
aluminium M4 dome head
grip range: 0,5 - 6,0 mm
item no.: 10.894.040.600

OPTO® multigrip blind rivet
nut SFM 4-60
steel M4 dome head
grip range: 0,5 - 6,0 mm
item no.: 10.895.040.600

OPTO® multigrip blind rivet
nut ASM 4-60 aluminium
M4 countersunk head
grip range: 1,5 - 6,0 mm
item no.: 10.894.400.600

OPTO® multigrip blind rivet
aluminium/steel
4,0 x 9,5 dome head
grip range: 1,2 - 6,4 mm
item no.: 10.600.040.095

RIFBOLT® blind rivet bolt
steel
M5 dome head
grip range: 0,5 - 2,0 mm
item no.: 10.880.052.010

OPTO® multigrip blind rivet
nut AFM 5-60
aluminium M5 dome head
grip range: 0,5 - 6,0 mm
item no.: 10.894.050.600

OPTO® multigrip blind rivet
nut SFM 5-60
steel M5 dome head
grip range: 0,5 - 6,0 mm
item no.: 10.895.050.600

OPTO® multigrip blind rivet
nut ASM 5-60 aluminium
M5 countersunk head
grip range: 1,5 - 6,0 mm
item no.: 10.894.500.600

OPTO® multigrip blind rivet
aluminium/steel
4,8 x 10,3 dome head
grip range: 1,5 - 6,0 mm
item no.: 10.600.048.103

RIFBOLT® blind rivet bolt
steel
M6 dome head
grip range: 0,5 - 2,5 mm
item no.: 10.880.062.510

OPTO® multigrip blind rivet
nut AFM 6-60
aluminium M6 dome head
grip range: 0,5 - 6,0 mm
item no.: 10.894.060.600

OPTO® multigrip blind rivet
nut SFM 6-60
steel M6 dome head
grip range: 0,5 - 6,0 mm
item no.: 10.895.060.600

OPTO® multigrip blind rivet
nut SSM 6-60 steel
M6 countersunk head
grip range: 1,5 - 6,0 mm
item no.: 10.895.600.600

OPTO® multigrip blind rivet
aluminium/steel
6,4 x 15 dome head
grip range: 2,0 - 8,0 mm
item no.: 10.600.064.150

RIFBOLT® blind rivet bolt
steel
M8 dome head
grip range: 1,0 - 3,0 mm
item no.: 10.880.083.015

OPTO® multigrip blind rivet
nut AFM 8-75
aluminium M8 dome head
grip range: 0,5 - 7,5 mm
item no.: 10.894.080.750

OPTO® multigrip blind rivet
nut SFM 8-75
steel M8 dome head
grip range: 0,5 - 7,5 mm
item no.: 10.895.080.750

OPTO® multigrip blind rivet
nut SSM 8-75 steel
M8 countersunk head
grip range: 1,5 - 7,5 mm
item no.: 10.895.800.750

Accessories MULTI 5

each with 1 piece nose piece 3,0/3,2 mm; 4,0 mm; 4,8/5,0 mm; 6,0 mm; 6,4 mm for blind rivets, each with 1 piece conversation kit for blind rivet nuts M4, M5, M6, M8 and M10, each with 1 piece threaded sleeve for blind rivet bolts M4, M5, M6 and M8

Item no. 35.500.600.894

Tool

1 piece MULTI 5 lever tool with fold-away-arms
item no.: 310.500.000.000

BATTERY RIVETERS



up to 5.0 mm

RivdomONE^{16V}

Now with *plus* charging technology



up to 7.8 mm

Rivdom TWO 2.8^{20V}

Maximum Power.

DMSD2G
Process monitoring

Mobile. Versatile. Trendsetting.

Rivdom® and RivSmart®-battery riveters.

Two names, one family for **innovative, modern solutions in mobile blind riveting.**

All the tools are characterised by outstanding performance data, ergonomic design with consistent weight reduction, large scope of supply and interesting additional options with the best price/performance ratio.

Benefit from our **decades of experience** in the development and production of hand-held riveters, pneumatic tools and automation solutions – **designed by HONSEL.**

up to 6.4 mm

Rivdom TWO 20V

Perfect also for high-strength blind rivets.

up to 5.0 mm

Rivsmart

Small, light, smart.



Winner of the "ROUTE TO FASTENER INNOVATION" prize at the Fastener Fair 2017 in Stuttgart.



up to 5.0 mm

NEW!

Rivdom ZERO

COMPACT. LIGHTWEIGHT. SIMPLE. POWERFUL.



RivdomZERO^{12V}

COMPACT. LIGHTWEIGHT. SIMPLE. POWERFUL.



up to 5.0 mm

“Really light and handy. I don’t need any tools for maintenance – and a brushless motor. THAT is my new battery riveter.”



The latest motor technology
Brushless and wear-free.

The newly developed brushless DC (BLDC) motor guarantees a very long and practically wear-free life-cycle. Low current consumption and reduced heat development increase the battery life and efficiency.



TOOL-FREE MAINTENANCE



Clamping jaws and nosepieces can be replaced quickly and easily on the spot.

The new mini

RivdomZERO^{12V} has the ultra-compact housing already known from the RivSmart®, a brushless motor and the RivdomPLUS charging technology.

Wear parts can be changed without the use of tools and the **weight of only 1.3 kg** guarantees maximum working comfort!

Get to know it now!

PRACTICAL DETAILS



Belt clip (alternatively rivet application plate)



Hanger bracket for balancer



LED-illuminated riveting point



Robust, transparent mandrel container (various sizes available as options!)



Plastic box for nosepieces

RivdomZERO^{12V}

Individual return mode setting

When using **manual return mode**, the trigger has to remain pressed until the rivet is sheared. When the trigger is released, the tool moves back to the front starting position. In addition, RivdomZERO^{12V} offers an **automatic return mode**. Here the trigger merely has to be pressed slightly to start the automatic setting process. Immediately after the drop in the measured force with the shearing of the rivet mandrel, the tool moves back automatically to the starting position to keep **the riveting cycle as short as possible**.

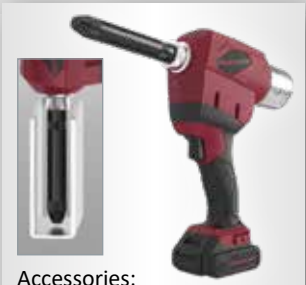

Accessories:
Extended front sleeves
for recessed riveting points.

Compact dimensions.

Thanks to the removable transparent mandrel container, the tool can be further shortened for **unrivalled ease of handling** for even the most confined installation points.



L-BOXX®



Sturdy and flexible

The innovative system packaging solution with added value. Our L-Boxx is also compatible with all L-Boxxes from other manufacturers.



Safety

Integrated mandrel safety switch in accordance with the Machinery Directive.

ERGONOMICS



Outstanding ergonomics, rubberised universal handle for all hand sizes.



Maximum comfort thanks to rotation trigger with very low trigger force/short trigger travel.

Rivdomplus

Charging technology

Future-oriented charging technology - perfected battery management

The powerful 12 V/2,0 Ah Li ion batteries are fully charged after **less than 30 minutes** – the **90 % charge** is reached after **only approx. 20 minutes**, so that the charging cycle is always shorter than the battery-consuming working time!

The state-of-charge can be monitored with the **display on every battery**.

12V/4.0 Ah batteries are available as optional accessories!

High-quality electronic fast charger with **automatic identification of the battery used**.

12 V, 16 V and 20 V batteries from the Rivdom family can be charged using the same charger.

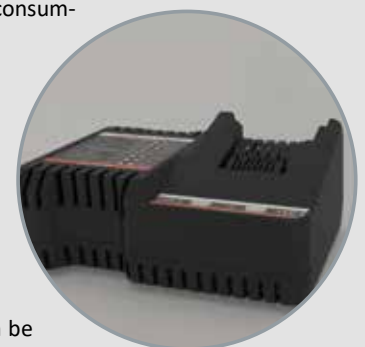

Spare parts

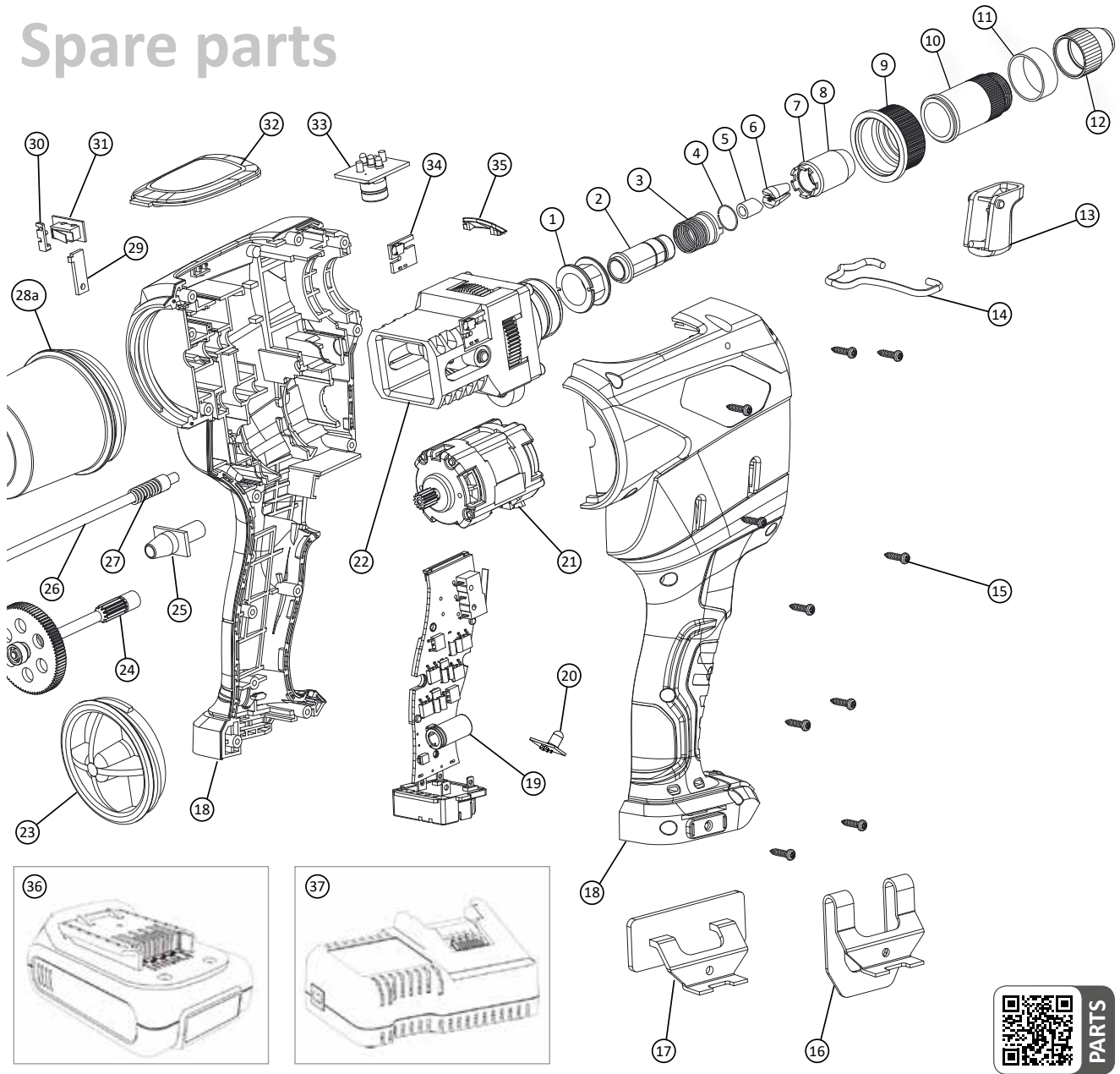

Facts



2.4	3.0	3.2	4.0	4.8	5.0	6.0	6.4	8.0
Aluminium								
Steel								
Stainless steel								
Copper alloys								



max. 3.4 mm



< 30 min.



8,500 N



1.3 kg (incl. battery)



20 mm



RivdomZERO battery riveter incl. 12 V/2.0 Ah battery (number depending on variant) with optical charge state indicator, 4x standard nosepiece in box, Rivdom-PLUS quick charger, mandrel container, belt clip, hanger and cover cap in L-Boxx with coloured sales sleeve.

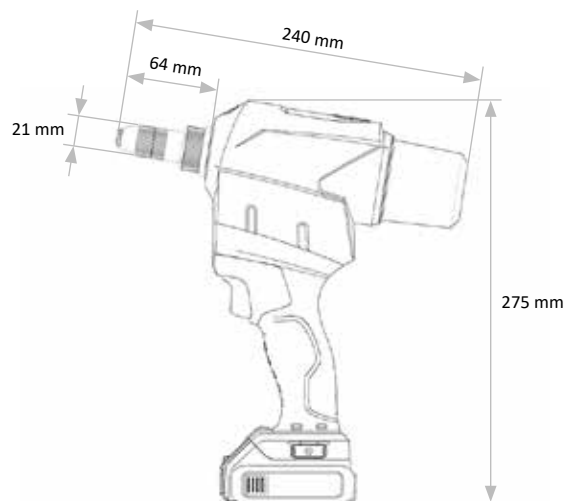

ZERO

Tool

320.210.000.000-010-1	RivdomZERO 12V incl. 1 x 12 V/2.0 Ah battery in L-Boxx
320.210.000.000-020-1	RivdomZERO 12V incl. 2 x 12 V/2.0 Ah battery in L-Boxx

Accessories

36	321.200.000.021	Li-Ion RivdomPLUS battery 12 V/2.0 Ah -scope of delivery-
p. 185	321.200.000.022	Li-Ion RivdomPLUS battery 12 V/4.0 Ah
37	321.500.000.001	Universal quick charger 200 V (12 V/16 V/20 V)
p. 185	321.200.000.072	Extended front sleeve 80 mm (available length 120 mm), extensions can be combined
see below	321.500.000.003	Multiple charging station
see below	321.500.000.004	Adapter multiple charging station for 1 x RivdomPLUS battery
28a	321.200.000.031	Mandrel container S (5.5 cm) -scope of delivery-
28b	321.300.100.031	Mandrel container L (8.0 cm)
28c	321.401.000.030	Mandrel container L+ (8.0 cm)
28d	321.501.000.030	Mandrel container XL+ (11.0 cm)
S. 201	321.200.000.018	Colored union ring (blue, gold, red, black)
14	321.200.000.029	Hanger -scope of delivery-
16	321.200.000.006	Belt clip -scope of delivery-
17	321.200.000.005	Name plate
23	321.401.000.004	Cover cap -scope of delivery-



Spare and Wear Parts

1	321.200.000.020	Dummy-Sensorring
2	321.200.000.054	Spacer
3	321.200.000.055	Quick release ring + spring
4	321.200.000.056	Quick release c-ring
5	321.200.000.017	Guide sleeve
6	311.002.000.132	Clamping jaws (1 set = 2 pcs.)
7	321.200.000.010	Scraper
8	321.200.000.016	Clamping sleeve
9	321.200.000.018	Union ring (silver)
10	321.200.000.015	Front sleeve
11	321.200.000.019	Rubber for union ring
13	321.200.000.033	Trigger and pressure spring
15	321.300.100.041	Housing screws (1 set = 10 pcs.)
18	321.200.000.032	Housing (left and right)
19	321.210.000.044	Electronic assembly complete
no fig.	321.300.100.039	Screws for electronic assembly (1 set = 2pcs.)
20	321.200.000.040	LED
21	321.200.000.001	Motor BLDC
22	321.200.000.000	Gear box complete incl. pinion shaft
24	321.200.000.003	Pinion shaft
25	321.200.000.043	Plastic tube
26	321.200.000.049	Mandrel discharge tube
27	321.200.000.014	Pressure spring
29	321.200.000.051	Mandrel safety switch - cover plate
30	321.200.000.050	Mandrel safety switch - lever and spring
31	321.200.000.052	Mandrel safety switch - switch and cabel
32	321.210.000.034	Info-Cover
33	321.210.000.037	Electronics with status LED
34	321.200.000.068	Hall-sensor + electronic
35	321.210.000.035	Hardcover

Nosepieces

12	321.200.000.122	Standard nose piece 2.4 mm
	321.200.000.123	Standard nose piece 3.0/3.2 mm
	321.200.000.124	Standard nose piece 4.0 mm
	321.200.000.125	Standard nose piece 4.8/5.0 mm
see info on the right top	321.200.000.132	Retension nose piece 2.4 mm
	321.200.000.134	Retension nose piece 3.0/3.2 mm
	321.200.000.136	Retension nose piece 4.0 mm
no fig.	321.200.000.138	Retension nose piece 4.8/5.0 mm
	321.200.932.070	Extended nosepiece (7mm) 3.0/3.2 mm
	321.200.940.070	Extended nosepiece (7mm) 4.0 mm
no fig.	321.200.950.070	Extended nosepiece (7mm) 4.8/5.0 mm
	321.200.932.200	Extended nosepiece (20mm) 3.0/3.2 mm
	321.200.940.200	Extended nosepiece (20mm) 4.0 mm
no fig.	321.200.950.200	Extended nosepiece (20mm) 4.8/5.0 mm
	321.200.000.511	Facade nosepiece 5.0 mm Head 11.0 mm
	321.200.000.514	Facade nosepiece 5.0 mm Head 14.0 mm
no fig.	321.200.000.516	Facade nosepiece 5.0 mm Head 16.0 mm
	321.200.000.524	Facade nosepiece 5.0 mm Head 24.0 mm
no fig.	321.200.008.401	Nosepiece FERRO®-BOLT blind rivets 4.8 mm

Container⁴

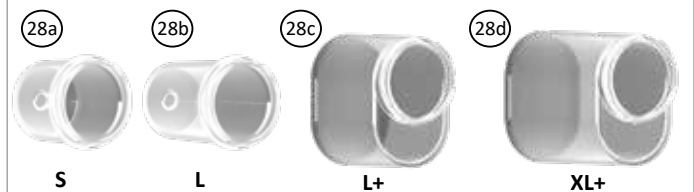

Charging⁴



Multiple charging station with interchangeable adapter system – suitable for RivdomPLUS batteries. Adapters for other manufacturers' batteries available on request.



RivdomONE^{16V}

up to 5.0 mm



“Our standard riveter for years. Reliable in every situation, and the latest generation with the new charging technology is recharged even faster.”

RivdomONE^{16V} will impress you

Blind rivets up to 5 mm diameter (all materials) are reliably set by the powerful motor and optimised clamping mechanism.

As with all other tools from the current Rivdom® generation, the Rivdom®ONE^{16V} has the high-quality Li ion batteries with RivdomPLUS charging technology and is supplied in the proven L-Boxx system.

The new housing is characterised by its outstanding ergonomics and reduced weight.

The new trigger has an extremely short travel/low trigger force and thus permits quick and comfortable working.

L-BOXX®



Sturdy and flexible

The innovative system packaging solution with added value.

Our L-Boxx is also compatible with all L-Boxxes from other manufacturers.

PRACTICAL DETAILS



Belt clip (alternatively rivet application plate)



Hanger bracket for balancer



LED-illuminated riveting point



Robust, transparent mandrel container (various sizes available as options!)



Plastic box for nosepieces



2.4 mm to



5.0 mm

ALL IN ONE. THE VARIO NOSEPIECE.

Do you often have to use different rivet sizes?

Use just **one** nosepiece and change **quickly and easily** between the diameters 2.4 mm, 3.0/3.2 mm, 4.0 mm and 4.8/5.0 mm – completely **without the use of tools!**

Only 20 mm diameter!



Extended front sleeves



Safety

Integrated mandrel safety switch in accordance with the Machinery Directive.



Compact dimensions

With cover cap for working without mandrel container.

ERGONOMICS



Outstanding ergonomics, low weight and rubberised handle.



Maximum comfort thanks to rotation trigger with very low trigger force/short trigger travel.

Rivdom plus
Charging technology

Future-oriented charging technology – perfected battery management

The powerful 16 V/2,0 Ah Li ion batteries are fully charged after **less than 30 minutes** – the **90 % charged** is reached after **only approx. 20 minutes**, so that the charging cycle is always shorter than the battery-consuming working time!

The state-of-charge can be monitored with the **display on every battery.**

16V/4.0 Ah batteries are available as optional accessories!

High-quality electronic fast charger with **automatic identification of the battery used.**

12 V, 16 V and 20 V batteries from the Rivdom family can be charged using the same charger.

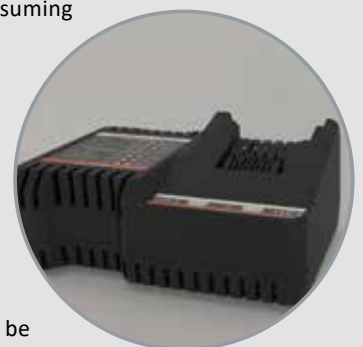

Spare parts

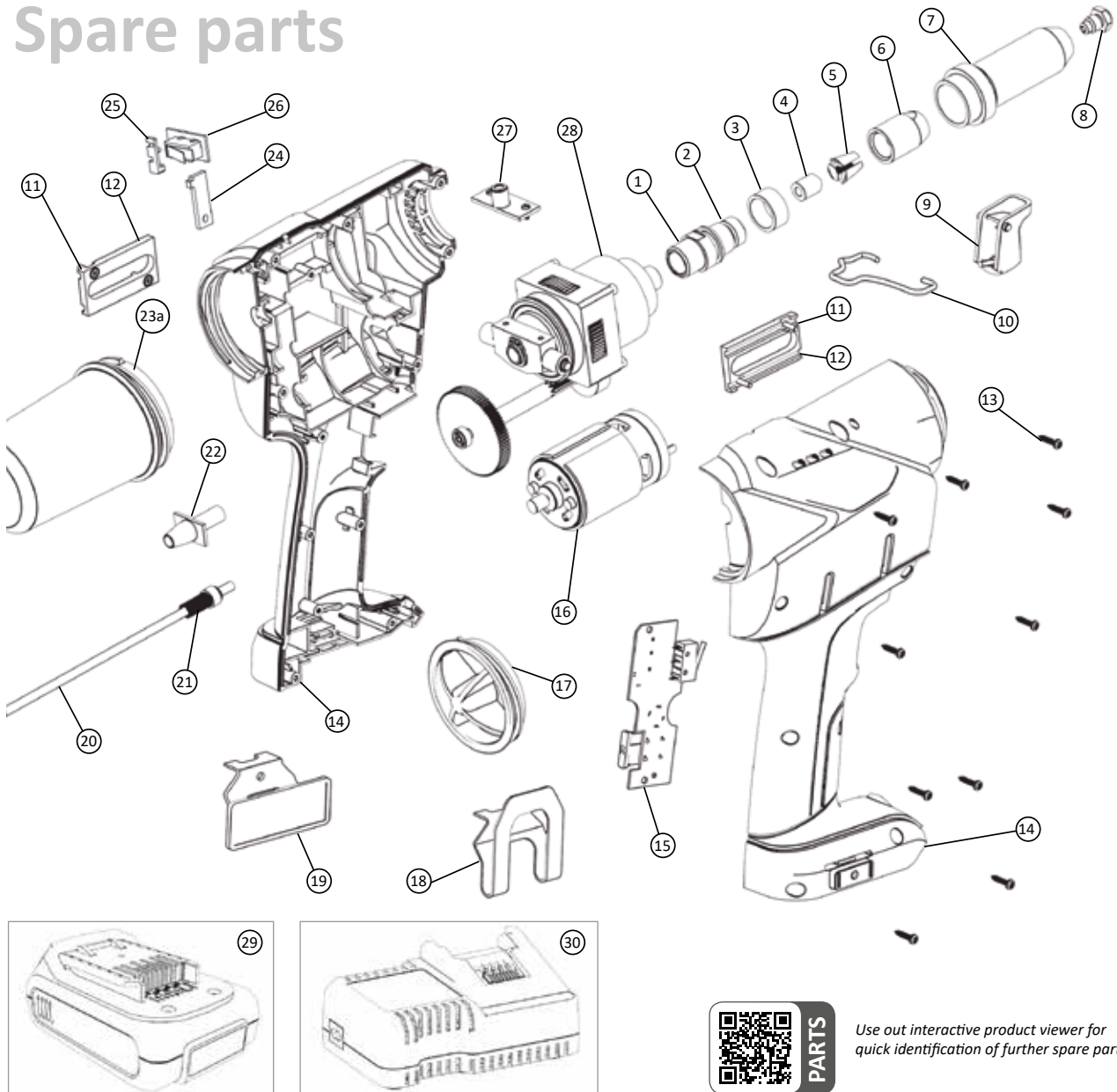

Use our interactive product viewer for quick identification of further spare parts.

Facts



	2.4	3.0	3.2	4.0	4.8	5.0	6.0	6.4	8.0
Aluminium	[Bar]								
Steel	[Bar]								
Stainless steel	[Bar]								
Copper alloys	[Bar]								



max. 3.4 mm



< 30 min.



10,000 N



1.8 kg (incl. battery)



21 mm



RivdomONE 16V battery riveter incl. 16V/2.0 Ah battery (number depending on variant) with optical charge state indicator, 4x standard nosepiece in box, Rivdom-PLUS quick charger, mandrel container, belt clip, hanger and cover cap in L-Box with coloured sales sleeve.

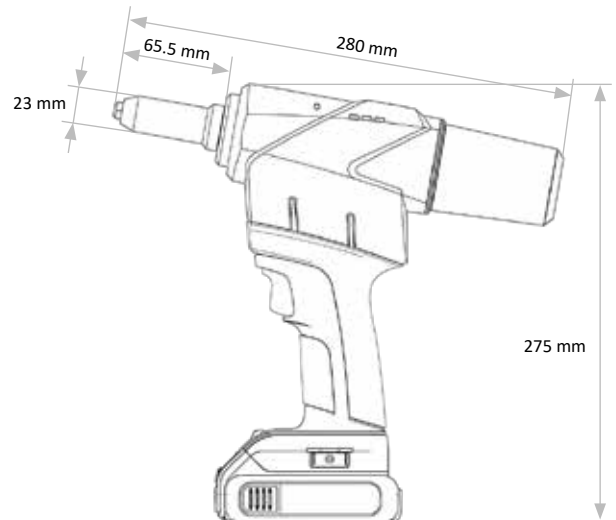

Tool

320.401.000.000-010-1	RivdomONE16V incl. 1 x 16V/2.0 Ah battery in L-Boxx
320.401.000.000-020-1	RivdomONE16V incl. 2 x 16V/2.0 Ah battery in L-Boxx

Accessories

29	321.401.000.021	Li-Ion RivdomPLUS battery 16 V/ <u>2.0 Ah</u>
p. 189	321.401.000.022	Li-Ion RivdomPLUS battery 16 V/ <u>4.0 Ah</u>
30	321.500.000.001	Universal quick charger 220 V (12 V/16 V/20 V)
see below	321.500.000.003	Multiple charging station
see below	321.500.000.004	Adapter multiple charging station for 1 x RivdomPLUS battery
p. 189	321.300.100.072	Extended Front sleeve (165 mm) or blind rivets up to 4 mm
23a	321.200.100.031	Mandrel container S (5.5 cm)
23b	321.300.100.031	Mandrel container L (8.0 cm) -scope of delivery-
23c	321.401.000.030	Mandrel container L+ (8.0 cm)
23d	321.501.000.030	Mandrel container XL+ (11.0 cm)
10	321.401.000.029	Hanger -scope of delivery-
17	321.401.000.004	Cover cap -scope of delivery-
18	321.200.000.006	Belt clip -scope of delivery-
19	321.200.000.005	Name plate



Retension nosepieces available as options ensure that the rivet cannot fall out of the tool even in vertical working position and one hand remains free, e.g. to hold the part.

Spare and Wear Parts

1	321.300.100.054	Spacer
2	321.300.100.010	Scraper
3	321.300.100.069	Extension sleeve
4	321.300.100.017	Guide sleeve
5	321.070.000.241	Clamping jaws (1 set = 3 pcs.)
6	321.300.100.016	Clamping sleeve
7	321.300.100.015	Front sleeve
9	321.200.000.033	Trigger and pressure spring
11	321.300.100.038	Screw for bearing
12	321.300.100.007	Gear box bearing
13	321.300.100.041	Housing screws (1 set = 10 pcs.)
14	321.401.000.032	Housing (left + right)
15	321.401.000.044	Electronic assembly complete
16	321.401.000.001	Motor
20	321.300.100.049	Mandrel discharge tube
21	321.300.100.021	Pressure spring
22	321.300.100.043	Plastic tube
24	321.401.000.051	Mandrel safety switch - cover plate
25	321.401.000.050	Mandrel safety switch - lever and spring
26	321.401.000.052	Mandrel safety switch - switch and cabel
27	321.300.100.036	Magnet holder with magnet
28	321.401.000.000	Gear box complete
no fig.	321.300.100.039	Screw for Electronic assembly
no fig.	321.300.100.046	Mounting wrench

Nosepieces

8	321.070.000.240	Standard nosepiece 2.4 mm
	321.085.000.123	Standard nosepiece 3.0/3.2 mm
	321.085.000.124	Standard nosepiece 4.0 mm
	321.085.000.125	Standard nosepiece 4.8/5.0 mm
see info on the right top	321.401.000.132	Retension nosepiece 2.4 mm
	321.401.000.134	Retension nosepiece 3.0/3.2 mm
	321.401.000.136	Retension nosepiece 4.0 mm
	321.401.000.138	Retension nosepiece 4.8/5.0 mm
	321.103.932.070	Extended nosepiece (7mm) 3.0/3.2 mm
	321.103.940.075	Extended nosepiece (7mm) 4.0 mm
	321.103.950.070	Extended nosepiece (7mm) 4.8/5.0 mm
	321.103.932.200	Extended nosepiece (20mm) 3.0/3.2 mm
	321.103.940.200	Extended nosepiece (20mm) 4.0 mm
	321.103.950.200	Extended nosepiece (20mm) 4.8/5.0 mm
	321.085.000.511	Facade nosepiece 5.0 mm Head 11.0 mm
	321.085.000.514	Facade nosepiece 5.0 mm Head 14.0 mm
	321.085.000.516	Facade nosepiece 5.0 mm Head 16.0 mm
	361.121.008.401	Nosepiece FERObOLT blind rivets 4.8 mm
	321.103.716.052	Nosepiece for folding blind rivets 5.2 mm
	321.300.100.071	VARIO nosepiece

Container⁴

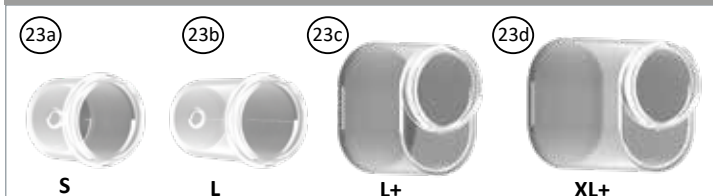

Charging⁴



Multiple charging station with interchangeable adapter system – suitable for VVG-PLUS batteries. Adapters for other manufacturers' batteries available on request.



Rivdom TWO^{20V}



“You simply notice that a great deal of experience in riveting technology has gone into the development of this tool...”

All in all – just perfect for me!”

up to 6.4 mm



RivdomTWO^{20V} – the powerful battery riveter

Designed and developed for blind rivets up to 6.4 mm diameter (all materials) – also for high-strength variants!

With a **setting force of 20,000 N** and a very large **stroke of 30 mm**, not only standard blind rivets and high-strength versions such as FERRO®-Bulb and FERRO®-Bolt or comparable products can be set, but also breakstem blind rivets can be quickly and reliably processed in one step.

L-BOX®



Sturdy and flexible

The innovative system packaging solution with added value.

Our L-Boxx is also compatible with all L-Boxxes from other manufacturers.

The Rivdom®TWO^{20V} also has a **new housing** with greatly improved ergonomics, the **new trigger with a travel of only 2 mm**, and the familiar **wide range of accessories** of the Rivdom family.

PRACTICAL DETAILS



Hanger bracket for balancer



LED-illuminated riveting point



Robust, transparent mandrel container
(various sizes available as options!)



Plastic box for nosepieces

RivdomTWO^{20V}

Individual return mode setting



When using **manual return mode**, the trigger has to remain pressed until the rivet is sheared. When the trigger is released, the tool moves back to the front starting position. In addition, RivdomTWO^{20V} offers an **automatic return mode**. Here the trigger merely has to be pressed slightly to start the automatic setting process. Immediately after the drop in the measured force with the shearing of the rivet mandrel, the tool moves back automatically to the starting position to keep the riveting cycle as short as possible.

ACCESSORIES



Extended front sleeves

ERGONOMICS



Outstanding ergonomics, low weight and rubberised handle.



Maximum comfort thanks to rotation trigger with very low trigger force/short trigger travel.



The latest motor technology Brushless and wear-free.

The newly developed brushless DC (BLDC) motor guarantees a very long and practically wear-free life-cycle. Low current consumption and reduced heat development increase the battery life and efficiency.

**BI BÜRSTENLOS
BRUSHLESS**



Safety
Integrated mandrel safety switch in accordance with the Machinery Directive.

Compact dimensions
With cover cap for working without mandrel container.

Rivdom plus⁺

Charging technology

Future-oriented charging technology – perfected battery management

The powerful 20 V/2,0 Ah Li ion batteries are fully charged after **less than 30 minutes** – the **90 % charged is reached after only approx. 20 minutes**, so that the charging cycle is always shorter than the battery-consuming working time!

The state-of-charge can be monitored with the **display on every battery**.

20V/4.0 Ah batteries are available as optional accessories!

High-quality electronic fast charger with **automatic identification of the battery used**.

12 V, 16 V and 20 V batteries from the Rivdom family can be charged using the same charger.

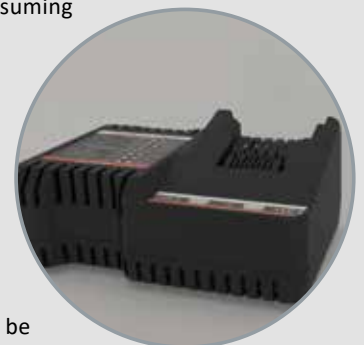

Spare parts

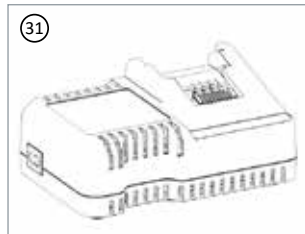
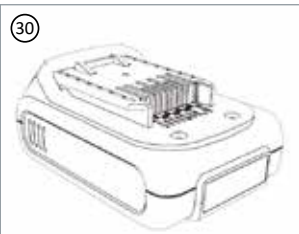
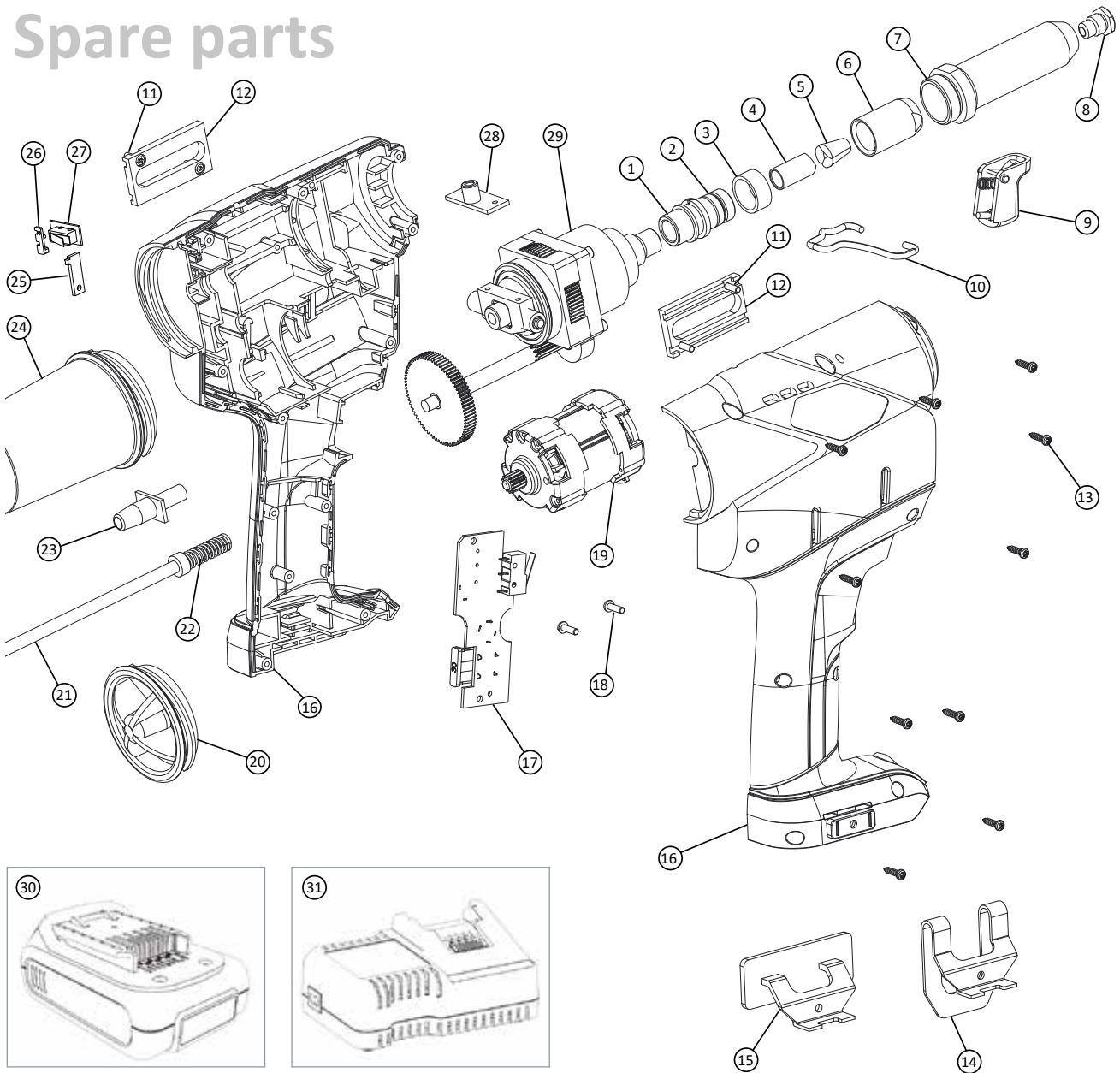

Facts



2.4	3.0	3.2	4.0	4.8	5.0	6.0	6.4	8.0
			Aluminium					
			Steel					
			Stainless steel					
			Copper alloys					



max. 4.8 mm



< 30 min.



20,000 N



2.0 kg (incl. battery)



30 mm



RivdomTWO 20 V battery riveter incl. 20 V/2.0 Ah battery (number depending on variant) with optical charge state indicator, 4x standard nosepiece in box, Rivdom-PLUS quick charger, mandrel container, belt clip, hanger and cover cap in L-Box with coloured sales sleeve.

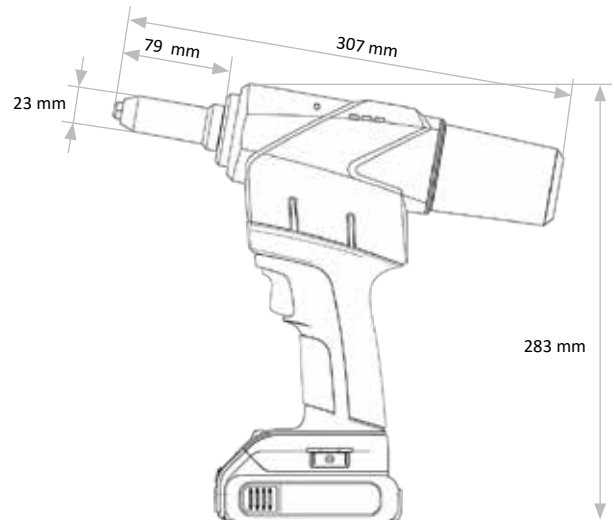



Tool

320.501.000.000-010-1	RivdomTWO 20V incl. <u>1</u> x 20 V/2.0 Ah battery in L-Boxx
320.501.000.000-020-1	RivdomTWO 20V incl. <u>2</u> x 20 V/2.0 Ah battery in L-Boxx

Accessories

30	321.500.000.021	Li-Ion RivdomPLUS battery 20 V/ <u>2.0 Ah</u>
p. 193	321.500.000.022	Li-Ion RivdomPLUS battery 20 V/ <u>4.0 Ah</u>
31	321.500.000.001	Universal quick charger 220 V (12 V/16 V/20 V)
see below	321.500.000.003	Multiple charging station
see below	321.500.000.004	Adapter multiple charging station for 1 x RivdomPLUS battery
p. 193	321.300.200.072	Extend front sleeve (210 mm) for blind rivets up to 4 mm
24a	321.200.100.031	Mandrel container S (5.5 cm)
24b	321.300.100.031	Mandrel container L (8.0 cm) -scope of delivery-
24c	321.401.000.030	Mandrel container L+ (8.0 cm)
24d	321.501.000.030	Mandrel container XL+ (11.0 cm)
10	321.401.000.029	Hanger -scope of delivery-
14	321.200.000.006	Belt clip
15	321.200.000.005	Name plate
20	321.401.000.004	Cover cap -scope of delivery-



Retension nosepieces available as options ensure that the rivet cannot fall out of the tool even in vertical working position and one hand remains free, e.g. to hold the part.

Spare and Wear Parts

1	321.300.200.054	Spacer
2	321.300.100.010	Scraper
3	321.300.200.069	Extension sleeve
4	321.300.200.017	Guide sleeve
5	321.120.000.011	Clamping jaws (1 set = 3 pcs.)
6	321.300.200.016	Clamping sleeve
7	321.300.200.015	Front sleeve
9	321.200.000.033	Trigger and pressure spring
11	321.300.100.038	Screw for bearing
12	321.300.200.007	Gear box bearing
13	321.300.100.041	Housing screws (1 set = 10 pcs.)
16	321.501.000.032	Housing (left + right)
17	321.501.000.044	Electronic assembly complete
18	321.300.100.039	Screw for Electronic assembly
19	321.501.000.001	Motor BLDC
21	321.300.200.049	Mandrel discharge tube
22	321.300.200.021	Pressure spring
23	321.300.200.043	Plastic tube
25	321.200.000.051	Mandrel safety switch - cover plate
26	321.401.000.050	Mandrel safety switch - lever and spring
27	321.401.000.052	Mandrel safety switch - switch and cable
28	321.300.100.036	Magnet holder with magnet
29	320.300.200.000	Gear box complete
no fig.	321.300.200.046	Mounting wrench

Nosepieces

8	321.120.000.124	Standard nosepiece 4.0 mm
	321.120.000.125	Standard nosepiece 4.8/5.0 mm
	321.120.000.126	Standard nosepiece 6.0 mm
	321.120.000.127	Standard nosepiece 6.4 mm
see info on the right top	321.501.000.132	Retension nosepiece 4.0 mm
	321.501.000.134	Retension nosepiece 4.8/5.0 mm
	321.501.000.136	Retension nosepiece 6.0 mm
	321.501.000.138	Retension nosepiece 6.4 mm
	321.123.940.070	Extended nosepiece (7 mm) 4.0 mm
	321.123.950.070	Extended nosepiece (7 mm) 4.8/5.0 mm
	321.123.960.070	Extended nosepiece (7 mm) 6.0 mm
	321.123.964.070	Extended nosepiece (7 mm) 6.4 mm
	321.123.940.200	Extended nosepiece (20 mm) 4.0 mm
	321.123.950.200	Extended nosepiece (20 mm) 4.8/5.0 mm
	321.123.960.200	Extended nosepiece (20 mm) 6.0 mm
	321.123.964.200	Extended nosepiece (20 mm) 6.4 mm
	321.120.000.511	Facade nosepiece 5.0 mm Head 11.0 mm
	321.120.000.514	Facade nosepiece 5.0 mm Head 14.0 mm
	321.120.000.516	Facade nosepiece 5.0 mm Head 16.0 mm
	361.121.008.401	Nosepiece FERO®-BOLT blind rivets 4.8 mm
	361.121.008.601	Nosepiece FERO®-BOLT blind rivets 6.4 mm
	321.123.716.052	Nosepiece for folding blind rivets 5.2 mm
	321.123.716.052	Nosepiece for folding blind rivets 6.3 mm



Use out interactive product viewer for quick identification of further spare parts.

Container⁴

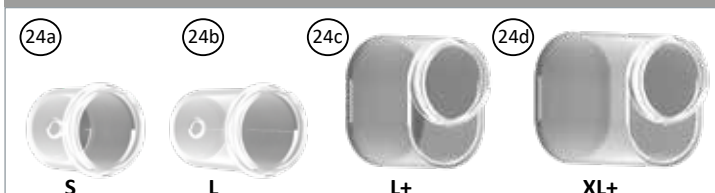

Charging⁴



Multiple charging station with interchangeable adapter system – suitable for VVG-PLUS batteries. Adapters for other manufacturers' batteries available on request.

RIVDOM®TWO2.8^{20V}

Battery-powered setting tool for blind rivets



Rivdom TWO2.8^{20V}

incl. retention nosepieces!



up to 8.0 mm!

"It doesn't get any better. Even rivets of 8 millimetre diameter are set in one stroke. I'm very impressed!"

2.8

Perfected for high-strength blind rivets with 6.4 and 7.8 mm diameter with grooved rivet mandrel!

Clamping jaws with trapezoidal grooves specially designed to match the grooves in the rivet mandrel and a modified clamping mechanism guarantee reliable and **positive setting** of FERRO®-BULB high-strength blind rivets (or comparable types) with a **mandrel diameter from 3.8 to 6.15/6.5 mm!**

Wear of the clamping jaws is minimised!

SEALING PLUGS

LOCKBOLT PINS

Rivdom can do more.

Together with our customers, we elaborate individual processing solutions on the basis of the Rivdom technology that go beyond the standard.

Our product developers benefit from the close proximity to the design engineers and can call together with Technical Sales on a modular system containing a large number of components and parts that can be quickly and easily modified.

Tool

320.528.000.000-010-1	RivdomTWO 2.8 20V incl. 1 x 20 V/2,0 Ah battery in L-Boxx
320.528.000.000-020-1	RivdomTWO 2.8 20V incl. 2 x 20 V/2,0 Ah battery in L-Boxx

Accessories

321.500.000.021-0-1	Li-Ion RivdomPLUS battery 20V /2,0 Ah
321.500.000.022-0-1	Li-Ion RivdomPLUS battery 20 V/4,0 Ah
321.500.000.001-0-10	Universal quick charger 220 V (12 V/16 V/20 V)
321.300.100.031	Mandrel container L (8,0 cm) -scope of delivery-
321.401.000.030	Mandrel container L+
321.501.000.030	Mandrel container XL+

TWO 2.8

Nosepieces / Spare and Wear Parts

321.528.000.066	Retension nosepiece 2.8 -6,4 mm-
321.528.000.067	Retension nosepiece 2.8 -7,8 mm-
321.528.045.080	Clamping jaws 2.8 (set)

Equipment details and further standard accessories on the pages of the **RivdomTWO^{20V}**

Facts



2.4	3.0	3.2	4.0	4.8	5.0	6.0	6.4	8.0
							Aluminium	
							Steel	
							Stainless steel	
							Copper alloy	

- max. 6.1 mm
- < 30 min.
- 24,000 N
- 2.1 kg (incl. battery)
- 30 mm
- RivdomTWO2.8 20V battery riveter incl. 20 V/2.0 Ah battery (number depending on variant) with optical charge state indicator, 2x retension nosepiece in box, Rivdom-PLUS quick charger, mandrel container, rivet application plate, belt clip, hanger and cover cap in L-Boxx.

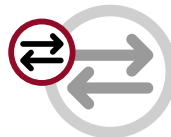
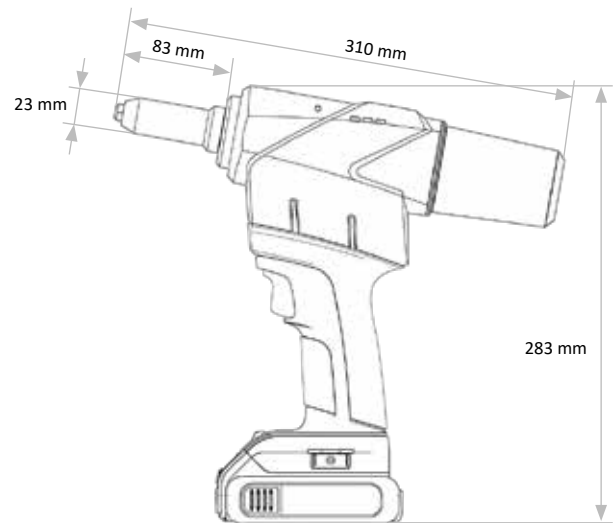

STRUCTURAL FASTENERS

The **contact force control** contributes to process reliability.

- **Health & safety**
The setting process starts only from a predefined contact force so that triggering without a workpiece is not possible.
- **Quality assurance**
The contact force on the workpieces ensures that the fastener and the components are positioned as defined.



The small, lightweight battery riveter
with process monitoring



Small. Light. Smart.

For blind rivets **up to 5.0mm** diameter!

“Innovative and fit for the future.

*RivSmart can be easily
integrated into our production
processes, and with its
documentation capabilities
helps us to continuously
optimise the production.”*

Rivdom is now smart. RivSmart.

Very small, very light and in touch with the world.

With RivSmart you can take the first step towards blind rivet processing 4.0 of tomorrow – on the basis of decades of experience in the development of high-quality riveting tools and individual riveting automation technology.

ERGONOMICS



The stringent optimisation of all the parts enables the RivSmart to impress with its **very low weight**.



Outstanding ergonomics, with rubberised universal handle for all hand sizes.



Maximum comfort thanks to rotation trigger with very low trigger force/short trigger travel.

Compact dimensions.

Thanks to the removable transparent mandrel container, the tool can be further shortened for **unrivalled ease of handling** for even the most confined installation points.



Safety

Integrated mandrel safety switch in accordance with the Machinery Directive.

TOOL-FREE MAINTENANCE



Clamping jaws and nosepieces can be replaced quickly and easily on the spot.



The latest motor technology Brushless and wear-free.

The newly developed brushless DC (BLDC) motor guarantees a very long and practically wear-free life-cycle. Low current consumption and reduced heat development increase the battery life and efficiency.

Rivdom plus

Charging technology



The powerful 12 V/2.0 Ah Li ion batteries are fully charged after **less than 30 minutes** – the **90 % charge is reached after only approx. 20 minutes**, so that the charging cycle is always shorter than the battery-consuming working time!

The state-of-charge can be monitored with the **display on every battery**, and **via the app and the display**.

12V/4.0 Ah batteries are available as optional accessories!

High-quality electronic fast charger with **automatic identification of the battery used**.

12 V, 16 V and 20 V batteries from the Rivdom family can be charged using the same charger.

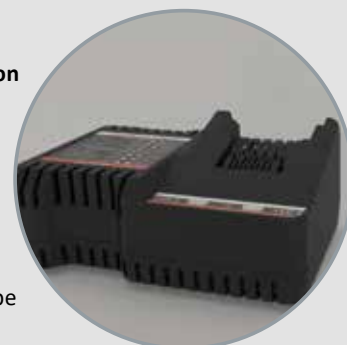



Intelligent controller

App-controlled
WiFi-connected



RivSmart can do more.

In addition to its outstanding riveting properties, RivSmart is prepared for integration into a networked production environment.



- OLED display (1.5") with 5 buttons
- Mobile control via Android or IOS app
- Management of several devices
- Wifi connectivity with radio frequencies 2.4 and 5 GHz
- Individual interface programming possible
- Many basic functions:
Countdown, various counters, statistics, signal tones
- Service functions:
Information on clamping jaw change, service intervals, emptying of mandrel container, job counter, live statistics,



Included in the scope of supply:
SD card as **internal memory** for reading out the documented data of the process stamp, even without permanent WiFi connection.

L-BOX®



Sturdy and flexible

The innovative system packaging solution with added value.
Our L-Boxx is also compatible with all L-BOXes from other manufacturers.

Documented process monitoring

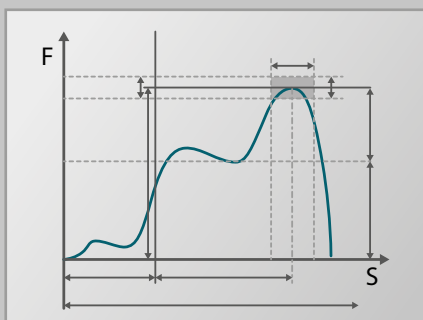

RivSmart is equipped with the **DMSD-lite process monitoring system** even in the standard version. This allows the correct setting of the rivet to be immediately checked and documented with a process stamp after every riveting.

The optional **DMSD 2G** and **HR version** with PLC interface or patented sensor systems offers complete documentation of each individual riveting with device number, time stamp, number, error codes, as well as various stroke and force measurements in separate process windows in text format.



Information on the DMSD 2G process monitoring system on pages 204-207

PRODUCTION OPTIMISATION -optional-

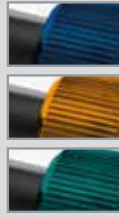

Colour coding of the union nut possible for **identification** of application, workplace or employees available as an accessory.

Also available: Plate for **marking** of the field of application installed in the same way as the belt clip.



EXTENDED SLEEVES -optional-



Extended front sleeves for recessed riveting points. Even here, as with the standard sleeve – only 21 mm diameter. Can be combined with extensions.

Individual return mode setting



When using **manual return mode**, the trigger has to remain pressed until the rivet is sheared. When the trigger is released, the tool moves back to the front starting position.

In addition, RivSmart^{12V} offers an **automatic return mode**.

Here the trigger merely has to be pressed slightly to start the automatic setting process. Immediately after the drop in the measured force with the shearing of the rivet mandrel, the tool moves back automatically to the starting position to keep the **riveting cycle as short as possible**.

PRACTICAL DETAILS



Belt clip – RivSmart is always to hand



LED-illuminated riveting point



Robust, transparent mandrel container (various sizes available as options!)



Plastic box for nosepieces

VVG tools from professionals for professionals

We have been developing and producing processing tools for blind rivet products within the HONSEL Group for decades. This experience and the passion to provide the user with innovative solutions to the demands of day-to-day work goes far beyond the product alone.

The **VIP service** for registered RivSmart users.

Download the RivSmart app and register within 30 days of the purchase! **Your benefits:**



Extension of the manufacturer's guarantee to three years!



Our experienced experts are at your disposal with **exclusive professional support** free of charge on the RivSmart hotline.



Free-of-charge pick-up and return service for maintenance and repair.



Free exchange tools and shorter lead times.



Regular software updates free of charge.

Spare parts

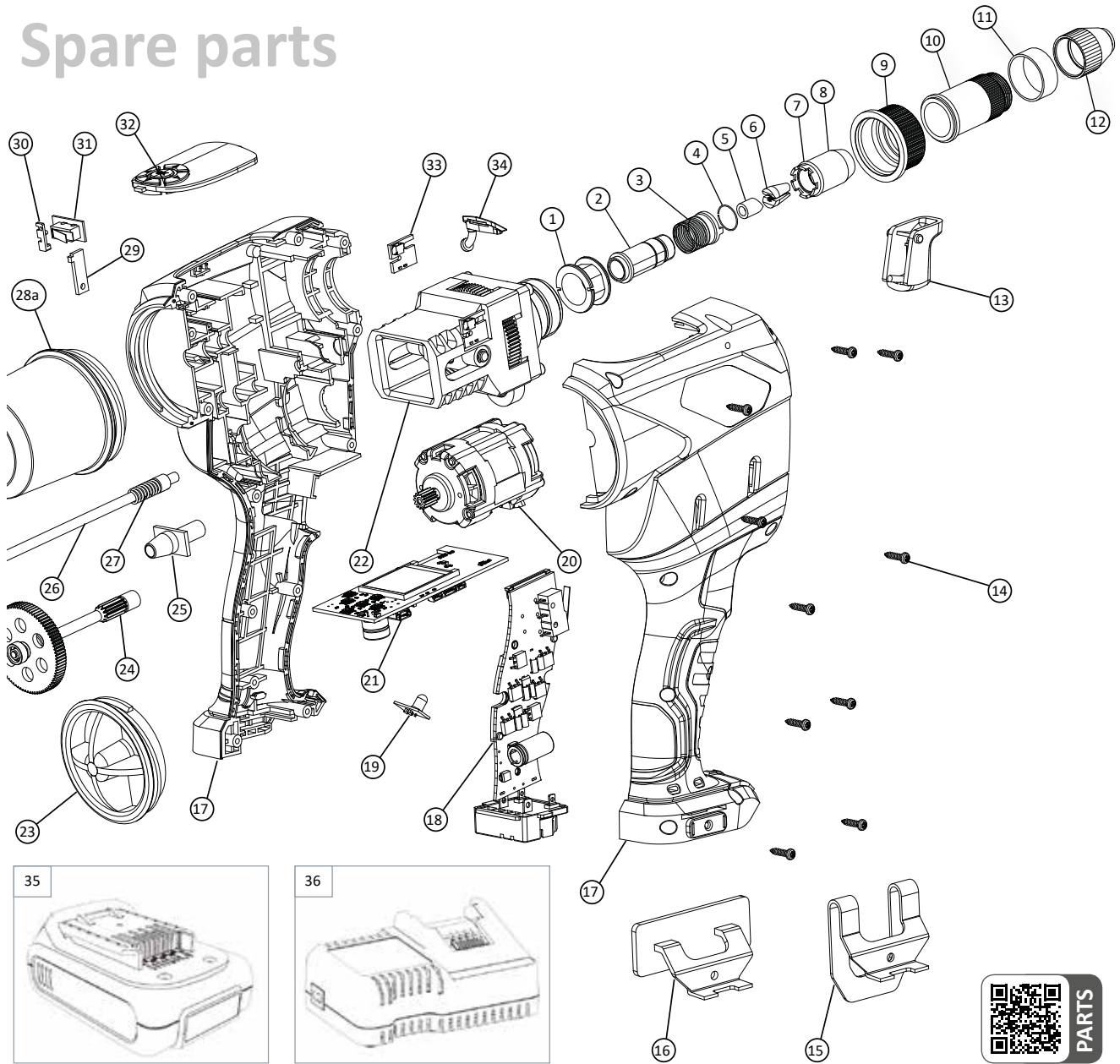

Facts



2.4	3.0	3.2	4.0	4.8	5.0	6.0	6.4	8.0
Aluminium								
Steel								
Stainless steel								
Copper alloys								



max. 3.4 mm



< 30 min.



8,500 N



1.3 kg (incl. battery)



20 mm



RivSmart battery riveter incl. 12 V/2.0 Ah battery (number depending on variant) with optical charge state indicator, 4x standard nosepiece in box, Rivdom-PLUS quick charger, mandrel container, belt clip, rivet application plate, hanger and cover cap in L-Boxx with coloured sales sleeve.

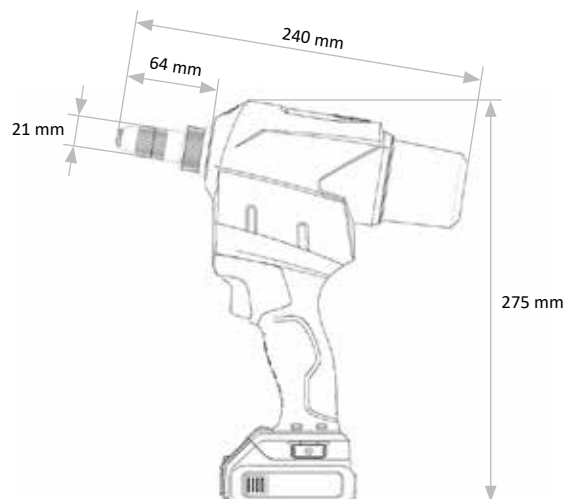

Tool

320.200.000.000-010-1	RivSmart <i>lite</i> incl. 1 x 12 V/2,0 Ah battery in L-Boxx
320.200.000.000-020-1	RivSmart <i>lite</i> incl. 2 x 12 V/2,0 Ah battery in L-Boxx

Accessories

35	321.200.000.021	Li-Ion RivdomPLUS battery 12 V/2,0 Ah
p. 199	321.200.000.022	Li-Ion RivdomPLUS battery 12 V/4,0 Ah
36	321.500.000.001	Universal quick charger 220 V (12 V/16 V/20 V)
p. 201	321.200.000.072	Extended front sleeve 80 mm (available length 120 mm), extensions can be combined
see below	321.500.000.003	Multiple charging station
see below	321.500.000.004	Adapter multiple charging station for 1 x RivdomPLUS battery
28a	321.200.000.031	Mandrel container S (5,5 cm)
28b	321.300.100.031	Mandrel container L (8,0 cm) -scope of delivery-
28c	321.401.000.030	Mandrel container L+ (8,0 cm)
28d	321.501.000.030	Mandrel container XL+ (11,0 cm)
p. 201	321.200.000.018	Colored union ring (blue, gold, red, black)
15	321.200.000.006	Belt clip -scope of delivery-
16	321.200.000.005	Name plate -scope of delivery-
23	321.401.000.004	Cover Cap -scope of delivery-

Spare and Wear Parts

1	321.200.000.020	Dummy-Sensorring
2	321.200.000.054	Spacer
3	321.200.000.055	Quick release ring + spring
4	321.200.000.056	Quick release c-ring
5	321.200.000.017	Guide sleeve
6	311.002.000.132	Clamping jaws (1 set = 2 pcs.)
7	321.200.000.010	Scraper
8	321.200.000.016	Clamping sleeve
9	321.200.000.018	Union ring (silver)
10	321.200.000.015	Front sleeve
11	321.200.000.019	Rubber for union ring
13	321.200.000.033	Trigger and pressure spring
14	321.300.100.041	Housing screws (1 set = 10 pcs.)
17	321.200.000.032	Housing (left and right)
18	321.200.000.044	Electronic assembly complete
19	321.200.000.040	LED
20	321.200.000.001	Motor BLDC
21	321.200.000.041	Control electronics
22	321.200.000.000	Gear box complete incl. pinion shaft (24)
24	321.200.000.003	Pinion shaft
25	321.200.000.043	Plastic tube
26	321.200.000.049	Mandrel discharge tube
27	321.200.000.014	Pressure spring
29	321.200.000.051	Mandrel safety switch - cover plate
30	321.200.000.050	Mandrel safety switch - lever and spring
31	321.200.000.052	Mandrel safety switch - switch and cable
32	321.200.000.034	Display protection with buttons
33	321.200.000.068	Hall-sensor + electronic
34	321.200.000.035	SD card soft cover
no fig.	321.300.100.039	Screw for Electronic assembly (1 set = 2 pcs.)

Nosepieces

12	321.200.000.122	Standard nose piece 2.4 mm
	321.200.000.123	Standard nose piece 3.0/3.2 mm
	321.200.000.124	Standard nose piece 4.0 mm
	321.200.000.125	Standard nose piece 4.8/5.0 mm
see info on the right top	321.200.000.132	Retention nosepiece 2.4 mm
	321.200.000.134	Retention nosepiece 3.0/3.2 mm
	321.200.000.136	Retention nosepiece 4.0 mm
no fig.	321.200.000.138	Retention nosepiece 4.8/5.0 mm
	321.200.932.070	Extended nosepiece (7mm) 3.0/3.2 mm
	321.200.940.070	Extended nosepiece (7mm) 4.0 mm
no fig.	321.200.950.070	Extended nosepiece (7mm) 4.8/5.0 mm
	321.200.932.200	Extended nosepiece (20mm) 3.0/3.2 mm
	321.200.940.200	Extended nosepiece (20mm) 4.0 mm
no fig.	321.200.950.200	Extended nosepiece (20mm) 4.8/5.0 mm
	321.200.000.511	Facade nosepiece 5,0 mm Head 11,0 mm
	321.200.000.514	Facade nosepiece 5,0 mm Head 14,0 mm
no fig.	321.200.000.516	Facade nosepiece 5,0 mm Head 16,0 mm
	321.200.000.524	Facade nosepiece 5,0 mm Head 24,0 mm
no fig.	321.200.008.401	Nosepiece FERRO®-BOLT blind rivets 4.8 mm

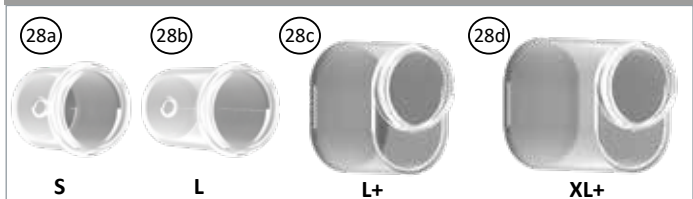
Container⁴

Charging⁴

Multiple charging station with interchangeable adapter system – suitable for RivdomPLUS batteries. Adapters for other manufacturers' batteries available on request.

Rivsmart
DMSD 2G

- Wireless for maximum flexibility
- In-process monitoring of blind rivet setting processes
- Early detection of quality deviations
- Minimisation of QA effort
- Quick feedback through transparency in the production process
- Traceable process results
- Reduction in additional test routines.

Wireless process monitoring



For more than 25 years, DMSD has been synonymous with **process monitoring in fastener technology**.

HONSEL received the first patent for process monitoring in blind rivet processing back in 1990. Since then the concept has been continuously optimised and is now available in the **DMSD 2G** version.

All VVG/HONSEL standard tool components, such as RivSys BZ & VNG, automation, manual workstations and hand-held tools for blind rivet nuts, blind rivets and coils can be interfaced to the **DMSD 2G**.

New measurement transducers which require a faster sampling rate, parallel and faster data processing and **new networking options** are the characteristics of the newly designed **DMSD 2G**.

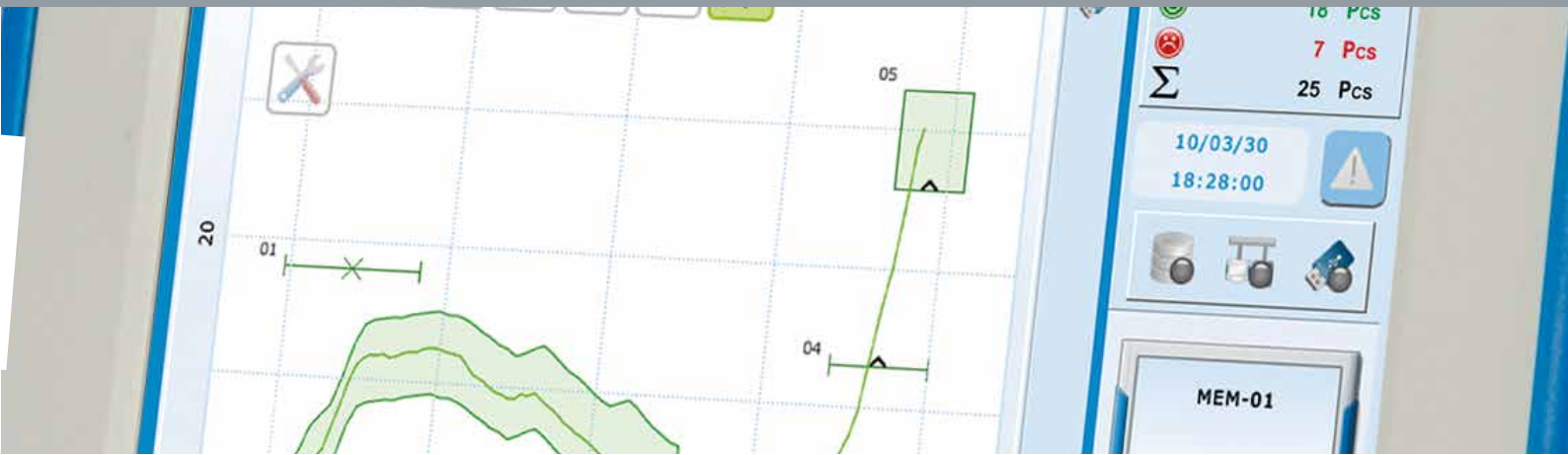

2G benefits at a glance

- Connection possibility for measurement transducers with different output signals from DMS to incremental and piezo measurement transducers without additional amplifiers
- The resolution of the distance measurement has been improved from 0.1 mm to 0.01 mm. This therefore complies with the VDA demand for 10 times resolution when recording with regard to the evaluation.
- The facility for monitoring maximum force and two additional control windows has been supplemented by two freely parametrisable control windows, even to the extent of envelope curve monitoring. It is possible to evaluate up to 10 evaluation elements in one measuring program.
- Up to 108 measuring programs can be stored in the monitoring.
- Up to 20 master programs are available for the monitoring.
- Parametrisation and programming take place via the firmware installed in the controller – no additional program is required.
- Operation and remote maintenance is possible using a VPN tunnel via a VNC viewer. The persons involved can access the functions of the software via the Internet and monitor the actions. The VNC viewer can also be connected to a large monitor.
- The measurement evaluation module (MEM) can be used with the display module (DIM) or also as a black box module without a display module.

DIM and MEM
directly connected

Display module – DIM



Measurement recording module – MEM

The measurement recording module can be connected to the display module via a connecting cable with a maximum cable length of 5 m or can be plugged in directly.

Almost any distance between the modules can be realised by incorporating DIMs and MEMs in a company-provided Ethernet. Alternatively, the measurement recording module (MEM) is directly connected to the display module (DIM).



Up to eight measurement recording modules can be connected to a display module for extended applications.

When using a VNC viewer, applications can also alternatively be implemented that do not have a display module.

Up to 8 MEMs can be connected to a DIM and displayed simultaneously.

As well as the last process values, a history of the previous setting processes can be called up via the MEM.

The process monitoring measuring programs and settings can be stored on a USB storage medium, from where they can also be restored.

The process values can be archived on a USB storage medium or on a server via Ethernet (USB storage medium, server or QDAS).

The process values can be stored in Q-DAS, XML, CSV, PDF, QDA-9 or IPM 5.0 format. Process values stored in CSV format can be subjected to further processing using Excel.

A scanner for recording the components can be directly attached to the MEM. If a scanner is incorporated, the code that is read in is also stored, making tracking possible.

Connection to a customer controller is possible via digital inputs and outputs and via a field bus (PROFINET, PROFIBUS DP and EtherCAT).

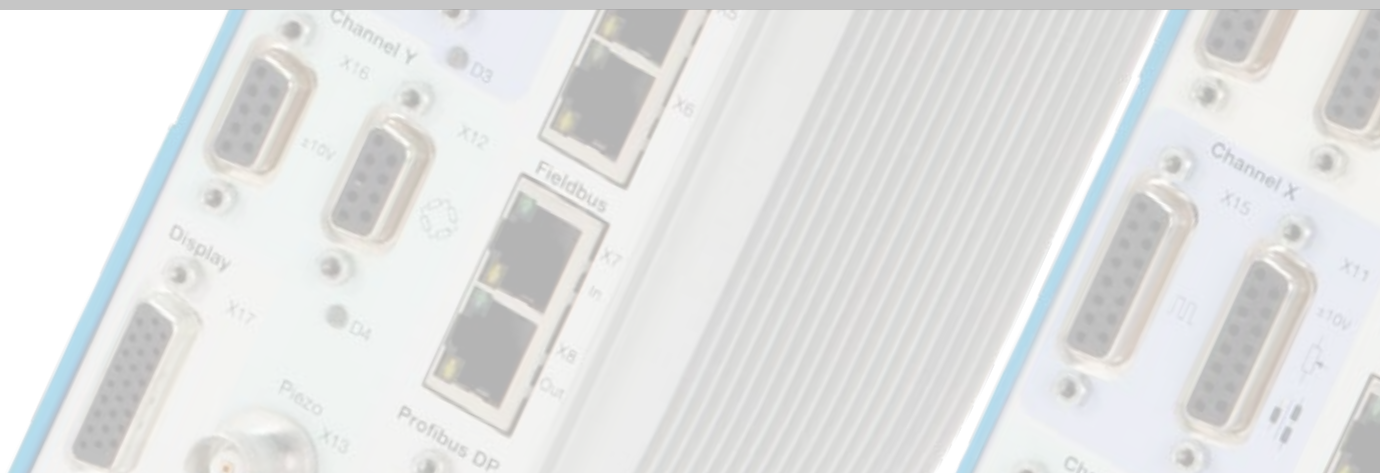

Connection possibility for hand-held tools

1. Hand scanner
2. USB storage medium
3. Server
4. Digital inputs (5x) and outputs (8x)
 - PROFINET
 - EtherCAT
 - PROFIBUS DP
5. RivSmart tools via WiFi
6. BZ and VNG components

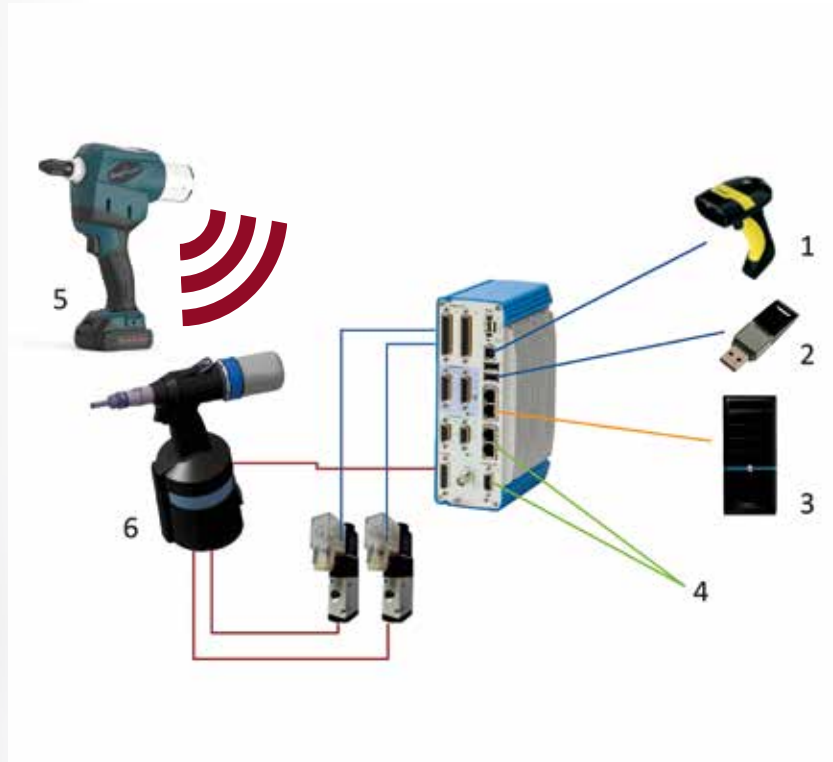

Connection between MEM and programming user interface

1. MEM fitted directly on DIM.
2. Distance between DIM and MEM up to 5 m via cable.
3. Operation via DIM connected via Ethernet.
4. Operation with VNC viewer on machine control unit via Ethernet.
5. Operation with VNC viewer on PC via Ethernet.
6. Remote maintenance via Internet and VPN.

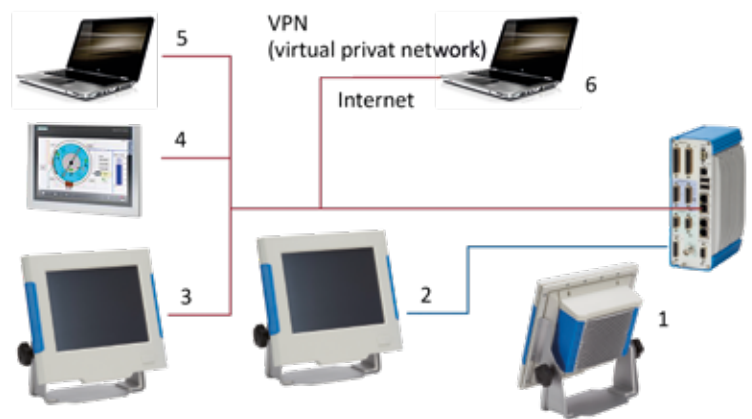

PNEUMATIC TOOLS



Pneumatic tools





i Decades of experience as well as **permanent optimization and further development** make the successful tools in the BZ and VNG series reliable partners in the industrial serial manufacturing and likewise in workshops and handicrafts.

A **robust construction** and **full equipment** including all necessary conversion parts and **extended accessories** as well as extensions like axial versions or angular rivet heads do not leave any option open.

For special applications we construct and manufacture **automations** or **process controls** according to your specifications.

BZ 103 A

Setting tool for blind rivets

pneumatic-hydraulic | with permanent or intervalic suction



BZ 103 A. The current version of the well-proven standard unit for reliable blind riveting.

A real classic: With reduced noise, very fast setting, with outstanding ergonomics and an extensive scope of supply with all the necessary accessories in high-quality packaging. Optimised nosepieces also ensure the reliable setting of blind rivets with very short studs. Individually adjustable suction air flow for the rivet stud.



Reliable, robust,
well proven in use.

	2,4	3,0	3,2	4,0	4,8	5,0	6,0	6,4	8,0
Aluminium	[Bar]								
Steel	[Bar]								
Stainless steel	[Bar]								
Copper alloys	[Bar]								

3,8 mm	5-7 bar	< 75 dB(A) (68,32)
1,8 kg	18 mm	2,4 liter
<ul style="list-style-type: none"> • 4 nosepieces • 1 set of clamping jaws • 1 bottle hydraulic oil / incl. re-fill unit • 2 mandrel collectors 	11.700 N at 7 bar	G 1/4 inside, installation left or right side

Item no. 320.103.000.000



BZ 103 A



Optimized. Very shallow standard nose pieces with reduced dog point improves the setting behavior.

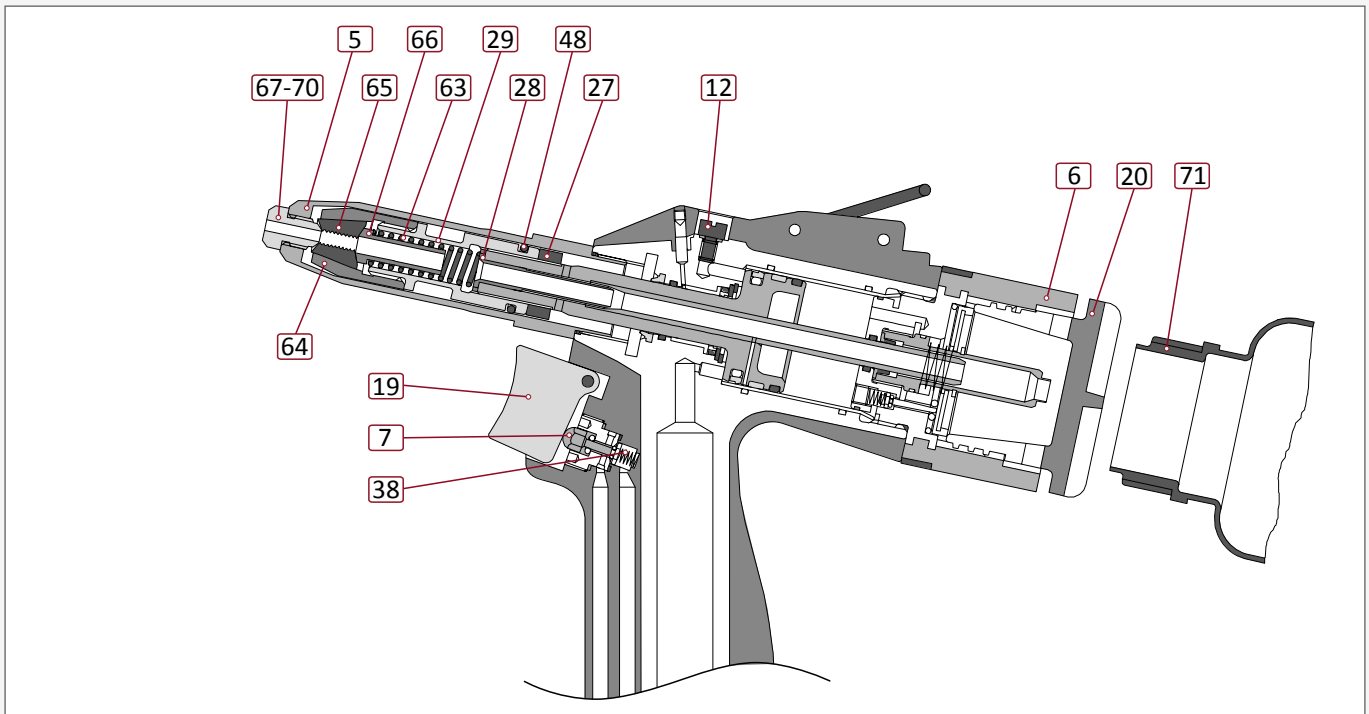

Spare / Wear Parts and Accessories

5	321.101.000.016	Front sleeve
6	321.102.000.006	Mandrel capture comple
7	321.102.000.007	Release valve
12	321.101.000.027	Oil drain plug including o-ring
19	321.102.000.016	Trigger
20	321.102.000.017	Closing cap mandrel capture
27	321.102.000.023	M12 x 3 capture nut
28	321.121.000.121	Vacuum nozzle
29	321.102.000.025	Spacer
38	321.102.000.036	Pressure spring trigger
48	321.101.000.042	O-ring 15.0 x 2.0 NBR 90° Shore
63	311.045.000.013	Pressure spring clamping mechanism
64	311.045.000.010	Clamping sleeve
65	321.070.000.241	Clamping jaws (1 set = 3 pcs.)
66	311.055.000.020	Guide sleeve
71	321.082.000.010	Mandrel collector
unten	321.101.000.091	Wind deflector BZ tools

Nosepieces

67	321.070.000.240	Standard nosepiece 2.4 mm
68	321.085.000.123	Standard nosepiece 3.0/3.2 mm
69	321.085.000.124	Standard nosepiece 4.0 mm
70	321.085.000.125	Standard nosepiece 4.8/5.0 mm
o. Abb.	321.103.932.070	Extended nosepiece (7mm) 3.0/3.2 mm
o. Abb.	321.103.940.075	Extended nosepiece (7mm) 4.0 mm
o. Abb.	321.103.950.070	Extended nosepiece (7mm) 4.8/5.0 mm
o. Abb.	321.103.932.200	Extended nosepiece (20mm) 3.0/3.2 mm
o. Abb.	321.103.940.200	Extended nosepiece (20mm) 4.0 mm
o. Abb.	321.103.950.200	Extended nosepiece (20mm) 4.8/5.0 mm
o. Abb.	321.085.000.511	Extended nosepiece 5.0 mm Head 11.0 mm
o. Abb.	321.085.000.514	Extended nosepiece 5.0 mm Head 14.0 mm
	321.085.000.516	Extended nosepiece 5.0 mm Head 16.0 mm
o. Abb.	361.101.008.401	Nosepieces FERRO-BOLT blind rivet 4.8 mm
	321.103.716.052	Nosepieces for folding blind rivets 5.2 mm
	321.085.009.124	CERTO® blind rivet 4.0 mm
	321.085.009.125	CERTO® blind rivet 4.8/5.0 mm



Wind deflector to divert the stud suction air flow.



PARTS

Use our interactive product viewer for quick identification of further spare parts.

Pneumatic accessories on p.223

Extended front sleeves and further accessories pp 216/217

Special nosepieces can be produced at short notice for specific customer applications.



BZ 123 A

Setting tool for blind rivets

pneumatic-hydraulic | with permanent or intervalic suction



MOVIE

BZ 123 A. The powerful rivet tool for blind rivets of up to 8.0 mm in diameter!

With a **very long stroke of 25 mm** it is also eminently suited for the setting of high-strength FERRO®-BOLT blind rivets. As with all pneumatic-hydraulic Honsel VVG rivet tools, it offers **reduced noise** and an optimised clamping mechanism with **outstanding ergonomics** and an **extensive scope of supply**.

Many special accessories are also available. Individual adaptations are possible.



Very powerful.
Large stroke.

	2,4	3,0	3,2	4,0	4,8	5,0	6,0	6,4	8,0	
				Aluminium						
				Steel						
				Stainless steel						
				Copper alloys						

4,8 mm	5-7 bar	< 75 dB(A) (68,32)
2,34 kg	25 mm	3,5 liter
<ul style="list-style-type: none"> • 4 nosepieces • 1 set of clamping jaws • 1 bottle hydraulic oil / incl. re-fill unit • 2 mandrel collectors 	18.700 N at 7 bar	G 1/4 inside, installation left or right side

Item no. 320.123.000.000



BZ 123 A



The BZ 123 A is ideally suited for the setting of high-strength FERRO®-BOLT blind rivets. It is essential to use the special nosepieces shown on the right to ensure proper and functional locking of the riveting mandrel.

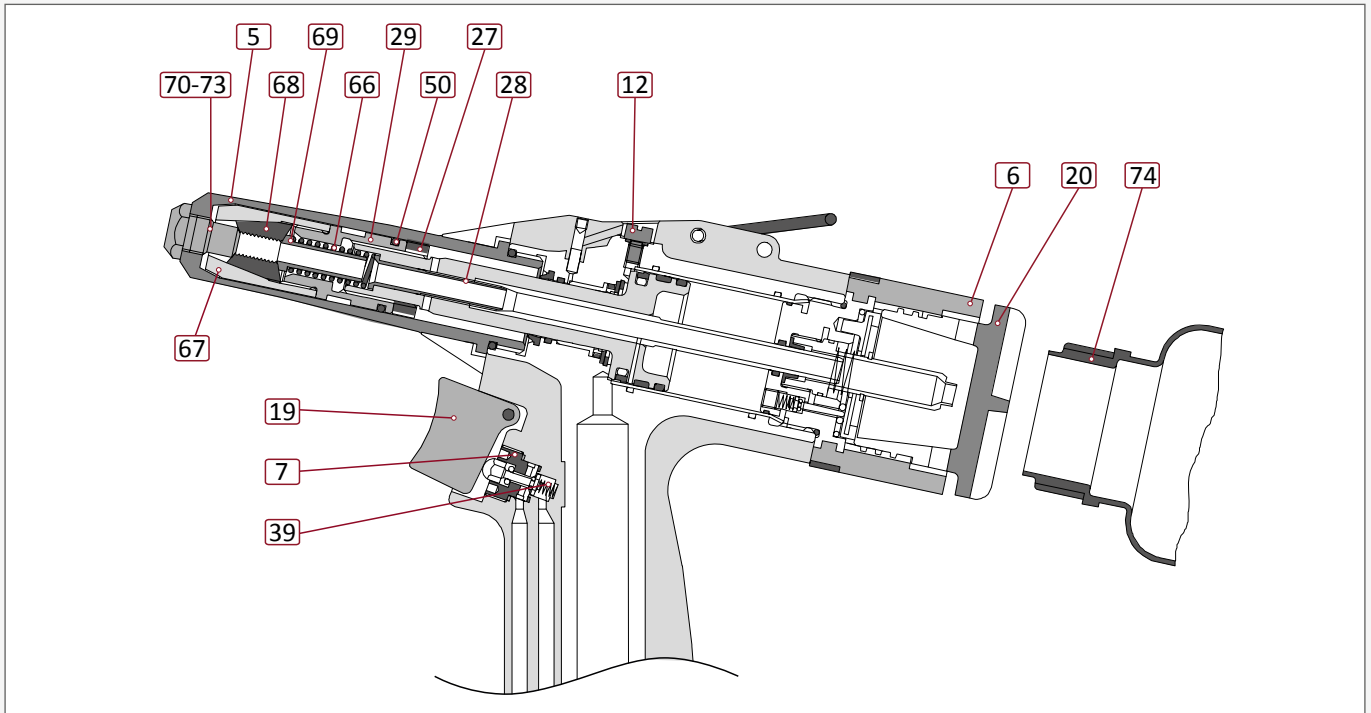

Spare / Wear Parts and Accessories

5	321.121.000.016	Front sleeve
6	321.102.000.006	Mandrel capture complete
7	321.102.000.007	Release valve
12	321.101.000.027	Oil drain plug including o-ring
19	321.102.000.016	Tirgger
20	321.102.000.017	Closing cap mandrel capture
27	321.122.000.023	M14 x 1,5 capture nut
28	321.221.000.014	Vacuum nozzle
29	321.122.000.025	Spacer
39	321.102.000.036	Pressure spring trigger
50	321.120.000.014	O-ring 15.0x2.0 NBR 90°Shore
66	311.045.000.013	Pressure spring clamping mechanism
67	321.120.000.012	Clamping sleeve
68	321.120.000.011	Clamping jaws (1 set = 3 pcs.)
69	321.120.000.010	Guide sleeve
71	321.082.000.010	Mandrel collector
unten	321.221.000.065	Extended mandrel collector

Nosepieces

70	321.120.000.124	Standard nosepiece 4.0 mm
71	321.120.000.125	Standard nosepiece 4.8/5.0 mm
72	321.120.000.126	Standard nosepiece 6.0 mm
73	321.120.000.127	Standard nosepiece 6.4 mm
o. Abb.	321.123.940.070	Extended nosepiece (7mm) 4.0 mm
o. Abb.	321.123.950.070	Extended nosepiece (7mm) 4.8/5.0 mm
o. Abb.	321.123.960.070	Extended nosepiece (7mm) 6.0 mm
	321.123.964.070	Extended nosepiece (7mm) 6.4 mm
o. Abb.	321.123.940.200	Extended nosepiece (20mm) 4.0 mm
o. Abb.	321.123.950.200	Extended nosepiece (20mm) 4.8/5.0 mm
o. Abb.	321.123.960.200	Extended nosepiece (20mm) 6.0 mm
	321.123.964.200	Extended nosepiece (20mm) 6.4 mm
o. Abb.	321.120.000.511	Facade nose piece 5.0 mm Head 11.0 mm
o. Abb.	321.120.000.514	Facade nose piece 5.0 mm Head 14.0 mm
	321.120.000.516	Facade nose piece 5.0 mm Head 16.0 mm
o. Abb.	361.121.008.401	Nosepieces FER0-BOLT blind rivet 4.8 mm
	361.121.008.601	Nosepieces FER0-BOLT blind rivet 6.4 mm
	321.123.716.052	Nosepieces for folding blind rivets 5.2 mm
	321.123.716.063	Nosepieces for folding blind rivets 6.3 mm



Extended collecting bin



PARTS

Use our interactive product viewer for quick identification of further spare parts.

Pneumatic accessories on p.223

Extended front sleeves and further accessories pp 216/217

Special nosepieces can be produced at short notice for specific customer applications.



BZ 123 A with special front sleeve and nose piece for mounting of lashing rails with FER0-BOLT blind rivets.

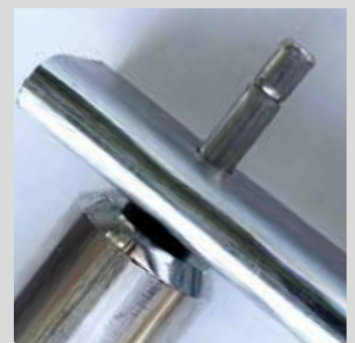

BZ 133 A

Setting tool for blind rivets

pneumatic-hydraulic | with permanent or intervalic suction



BZ 133 A. The powerful specialist for blind rivets of up to 8.0 mm in diameter!

Special high-strength FERRO®-BULB blind rivets are set conveniently and reliably according to the combination of the stroke and the very high setting force (24,000 N!). Our field service would be glad to provide you with all our pneumatic-hydraulic rivet tools. **Make an appointment!**



	2,4	3,0	3,2	4,0	4,8	5,0	6,0	6,4	8,0
					Aluminium				
					Steel				
					Stainless steel				
					Copper alloys				

- 4,8 mm
- 2,34 kg
- 4 nosepieces
 - 1 set of clamping jaws
 - 1 bottle hydraulic oil / incl. re-fill unit
 - 2 mandrel collectors
- 5-7 bar
- 18 mm
- 24.000 N at 7 bar
- < 75 dB(A)
- 3,5 liter
- G 1/4 inside, installation left or right side

Item no. 320.133.000.000

Spare / Wear Parts and Nosepieces

321.120.000.124	Nosepiece 4.0 mm
321.120.000.125	Nosepiece 4.8/5.0 mm
321.120.000.126	Nosepiece 6.0 mm
321.120.000.127	Nosepiece 6.4 / 8.0 mm
361.122.000.022	Clamping sleeve
321.120.000.010	Guide sleeve
361.122.000.020	Clamping jaws
321.120.000.014	O-ring clamping mechanism
311.045.000.013	Pressure spring clamping mechanism

BZ 133 A



Eminently suitable for use with FERRO®-BULB blind rivets!

BZ 143 A

Setting tool for blind rivets

pneumatic-hydraulic | with permanent or intervalic suction



Clamping jaws with **trapezoidal grooves specially designed to match the grooves in the rivet stud** and a modified clamping mechanism guarantee reliable and **positive setting** of FERO®-BULB high-strength blind rivets (or comparable types) with a stud diameter from 3.80 to 6.15/6.5 mm!

Wear of the clamping jaws is minimised!



Perfected
for high-strength blind rivets
with 6.4 and 7.8 mm diameter
and grooved rivet stud!



2,4	3,0	3,2	4,0	4,8	5,0	6,0	6,4	8,0
							Aluminium	
							Steel	
							Stainless steel	

- 6,5 mm
- 2,5 kg
- 2 nosepieces
 - 1 set of clamping jaws
 - 1 bottle hydraulic oil / incl. re-fill unit
 - 2 mandrel collectors
- 5-7 bar
- 18 mm
- 24.000 N at 7 bar
- < 75 dB(A)
- 3,5 liter
- G 1/4 inside, installation left or right side

Item no. 320.143.000.000

Spare / Wear Parts and Nosepieces

321.528.200.066	Retention nosepiece 6.4 mm
321.528.200.067	Retention nosepiece 7.8 mm
321.528.045.080	Clamping jaws
321.143.000.010	Guide sleeve
321.143.000.012	Clamping sleeve BZ143
321.143.000.013	Pressure spring clamping mechanism BZ143
321.143.000.016	Front sleeve BZ143
321.143.000.025	Piston extension BZ143



The grooves in the stud are matched to the FERO®-BULB blind rivet.



EXTENDED FRONT SLEEVES



Just 20 mm in diameter!

Extended front sleeves BZ 103 A (and BZ 102 A)

Conversion kit complete 130 mm	321.103.010.130
Conversion kit complete 170 mm	321.103.010.170
Conversion kit complete 210 mm	321.103.010.210

Extended front sleeves BZ 123 A (and BZ 122 A)

Conversion kit complete 130 mm	321.123.010.130
Conversion kit complete 170 mm	321.123.010.170
Conversion kit complete 210 mm	321.123.010.210

Particularly **low-lying rivet positions** can be excellently reached by the extended front sleeves. These are immediately available from stock in a length up to 210 mm and can be easily mounted to existing tools. The **extremely small diameter of 20 mm** makes processing possible even on very narrow, low-lying positions. There are no blind rivets with extended mandrels necessary!

ANGULAR RIVET HEADS



Around the corner.

To be able to set blind rivets at difficult-to-reach places various **angular rivet heads** for mounting onto the BZ 103 A are available. These angular rivet heads use setting forces between 5,000 N and 9,200 N with stroke length between 11 and 17 mm.

Accessories

Angular rivet head 5000/11 5,000 N - 12 mm Hub Height with nosepiece 85.6 mm - Width 24.0 mm - Length 117.0 mm	321.102.000.600-1-1
Angular rivet head 9200/17 - for inox blind rivets up to 5.0 mm!! 9,200 N - 17 mm Hub Height with nosepiece 88.0 mm - Width 34.2 mm - Length 121.0 mm	360.008.800.000-2-1



**Combinable with DMSD-
Process monitoring!**

Special suspension or a vertical handling of the riveting tool.

Riveting tools with a pistol grip are optimal in their ergonomics for horizontal processing.

For the processing in vertical direction, especially in industrial applications, modified versions with the following features are available:

- extended front sleeve with soft grip
- modified trigger
- rivet tool bracket AXIAL (usable horizontally and vertically without mounting)

BZ 103 A AXIAL Item no. 320.103.000.000-2-1

FOOT CONTROLLED TRIGGER AND MANDREL DISCHARGE

Mandrel discharge

The special screw fitting with plug connector can be used as an alternative to the normal mandrel collector. The sheared mandrels can be discharged through the 2 m long hose into a large mandrel collector. Frequent emptying is no longer necessary – you can continue to work without interruption. The workplace is kept free of sheared rivet mandrels.

Mandrel discharge complet 321.102.000.018-1-1

Foot controlled trigger

Actuation of the riveter by foot controlled trigger to have both hands free for part handling. Ideal in combination with installation in an existing fixture / worktop.

BZ 103 A prepared for foot controlled trigger 320.103.000.000-20-1

Foot controlled trigger complete 321.103.001.504-1-1

Front sleeve/lock nut for installation* 321.101.000.016-2-1



* not illustrated

VNG 703

Setting tool for blind rivet nuts and blind rivet bolts
 pneumatic-hydraulic | force-controlled



VNG 703. The force-controlled tool for fast handling of large numbers in serial manufacture..

The regulation through adjusting the necessary setting force guarantees that the blind rivet nut is always set in an **optimal and material-preserving** way. At the same time the VNG 703 features an **user-friendly conception** and **easy-to-use handling**. The switch from forward to backrun is extremely quick. Through light pressing on the mandrel the blind rivet nut is screwed on and after working screwed off automatically.



	M3	M4	M5	M6	M8	M10	M12
Aluminium							
Steel							
Stainless steel							
Steel (Mandrel)							
Weight	2,5 kg	< 75 dB(A) (68,32)		screwing 1800 rpm removing 2500 rpm			
AIR	4,4 liter	5-7 bar		G 1/4 inside, installation left or right side			
STROKE	9 mm	20.000 N at 7 bar		<ul style="list-style-type: none"> • conversion kits for blind rivet nuts • 1 bottle hydraulic oil / incl. re-fill unit 			

Item no. 320.703.000.000



VNG 703



Easy, **stepless adjustment** of the individually required setting force.



Special accessory angular adapter for keeping the needed rectangularity to the component.

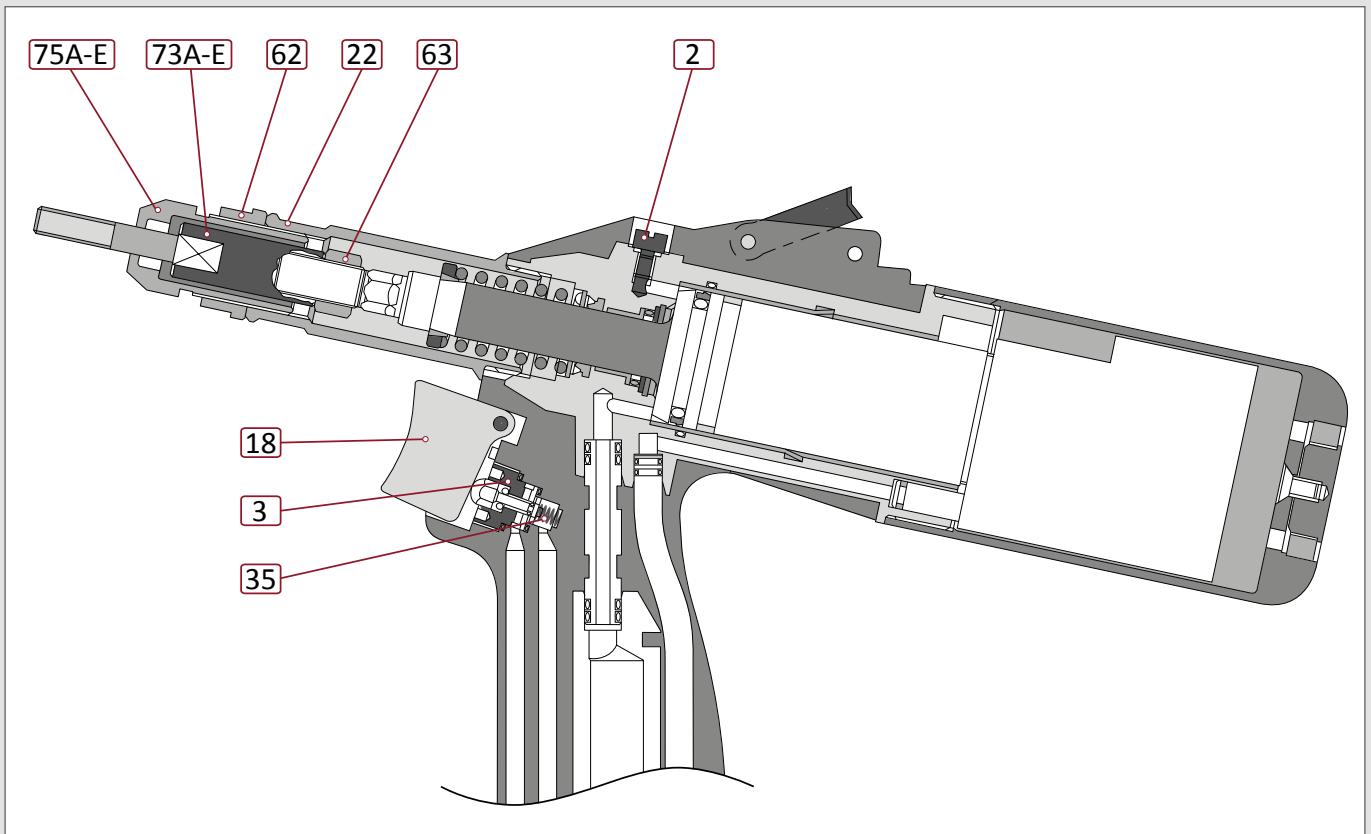

Spare and Wear Parts

2	321.101.000.027	Oil drain plug including o-ring
3	321.102.000.007	Release valve
18	321.102.000.016	Trigger
22	321.703.000.024	Front sleeve
35	321.102.000.036	Pressure spring trigger
62	321.801.000.074	Lock nut M18x1
63	361.802.191.075	Lock nut M9x0.75

Mandrels / Sleeves

73A	321.800.008.030	Mandrel M3
73B	321.800.008.040	Mandrel M4
73C	321.800.008.050	Mandrel M5
73D	321.800.008.060	Mandrel M6
73E	321.800.008.080	Mandrel M8
74B	321.800.009.040	Threaded sleeve Riffbolt M4
74C	321.800.009.050	Threaded sleeve Riffbolt M5
74D	321.800.009.060	Threaded sleeve Riffbolt M6

Nosepieces

75A	311.800.000.203	Nosepiece M3
75B	311.800.000.204	Nosepiece M4
75C	311.800.000.205	Nosepiece M5
75D	311.800.000.206	Nosepiece M6
75E	311.800.000.208	Nosepiece M8



PARTS

Use our interactive product viewer for quick identification of further spare parts.



Pneumatic accessories on p. 223



Special accessories, nosepieces and mandrels, for example, extended, or for UNC/UNF coarse threads or for inside riveting locations are available on request.



Outstandingly suited to the setting of OPTO® multi-range blind rivet nuts (► pages 90/91).

VNG 903

Setting tool for blind rivet nuts and blind rivet bolts
 pneumatic-hydraulic | stroke-controlled



MOVIE

VNG 903. The stroke-controlled solution for large tasks, optionally up to M12.

The mature design and the individual adjustment options make the VNG 903 your perfect partner for the powerful and reliable setting of all current forms of blind rivet nuts. These are **automatically threaded** onto the mandrel through light pressure. Threading is likewise stopped automatically; the threading time can be set. **Convenient, simple, practical.**

STROKE-CONTROLLED

STROKE-CONTROLLED

	M3	M4	M5	M6	M8	M10	M12
Material		Aluminium					optional
		Steel					optional
		Stainless steel					optional
Material		Steel					
Weight	2,7 kg						
Sound power level	< 75 dB(A) (68,32)						
Air consumption	7,5 liter						
Stroke	7 mm						
Force	29.000 N at 7 bar						
Speed	screwing 1800 rpm removing 2500 rpm						
Accessories	G 1/4 inside, installation left or right side						
	• conversion kits for blind rivet nuts						
	• 1 bottle hydraulic oil / incl. re-fill unit						

Item no. 320.903.000.000

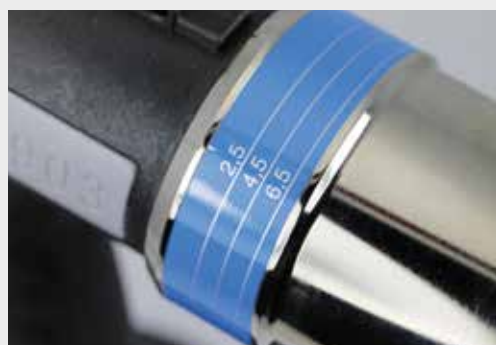

Exact adjustment of the setting stroke via scale on the adjustment cap.

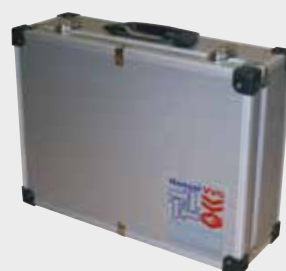

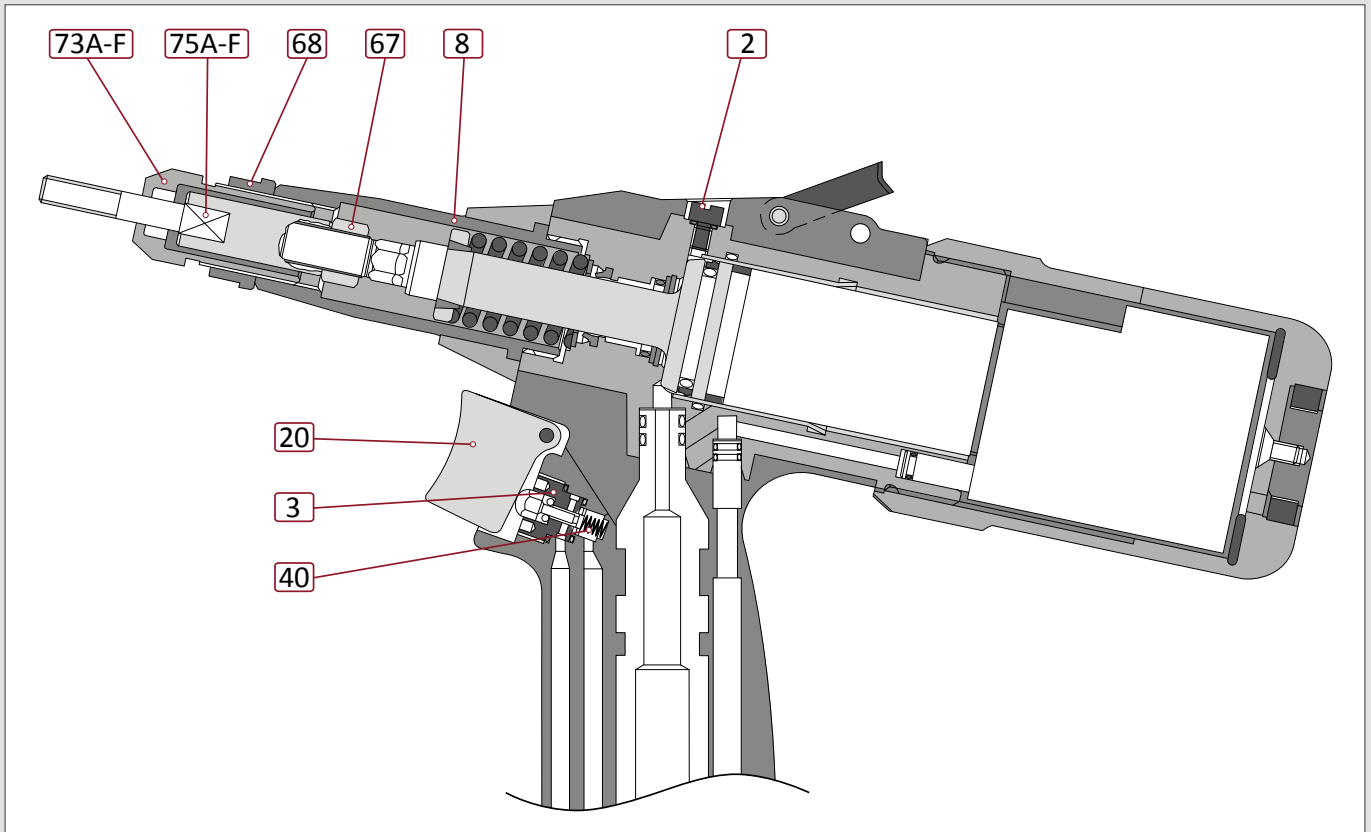

Spare and Wear Parts

2	321.101.000.027	Oil drain plug including O-ring
3	321.102.000.007	Release valve
20	321.102.000.016	Tirgger
8	321.903.000.016	Front sleeve
40	321.102.000.036	Pressure spring trigger
67	361.802.191.075	Lock nut M9x0,75
68	321.801.000.074	Lock nut M18x1

Nosepieces

73A	311.800.000.204	Nosepiece M4
73B	311.800.000.205	Nosepiece M5
73C	311.800.000.206	Nosepiece M6
73D	311.800.000.208	Nosepiece M8
73E	311.800.000.210	Nosepiece M10
73F	311.800.000.212	Nosepiece M12

Mandrels / Sleeves

75A	321.800.008.040	Mandrel M4
75B	321.800.008.050	Mandrel M5
75C	321.800.008.060	Mandrel M6
75D	321.800.008.080	Mandrel M8
75E	321.800.008.100	Mandrel M10
(75F)	321.800.008.120	Mandrel M12
74A	321.800.009.040	Threaded sleeve Rifbolt M4
74B	321.800.009.050	Threaded sleeve Rifbolt M5
74C	321.800.009.060	Threaded sleeve Rifbolt M6
74D	321.800.009.080	Threaded sleeve Rifbolt M8



PARTS

Use our interactive product viewer for quick identification of further spare parts.

Pneumatic accessories on p. 223

! Special accessories, nosepieces and mandrels, for example, extended, or for UNC/UNF coarse threads or for inside riveting locations are available on request.



VNG 903 in daily use. Guaranteed installation - powerful and reliable

Stroke circlip

The stroke circlip prevents any unwanted shifting of the adjusting cap.

> für VNG 701/801/802/903 : **321.801.000.080**



VNG 753

Setting tool for folding blind rivet nuts
 pneumatic-hydraulic | stroke-controlled



VNG 753. The special rivet tool for SFM-PL folding blind rivet nuts.

These can be set easily and perfectly through the **very long stroke** of up to 15 mm and the correspondingly **extended mandrel**.

See for yourself the capabilities of our pneumatic-hydraulic setting tools.

Our technical applications consultants would be glad to present them for you. Make an appointment.



	M3	M4	M5	M6	M8	M10	M12
		optional		steel		optional	
2.9 kg	< 75 dB(A) (68.32)	screwing 1800 rpm removing 2500 rpm		G 1/4 inside, installation left or right side			
7.5 l	5-7 bar	• conversion kits for folding blind rivet nuts M6 and M8		• 1 bottle hydraulic oil / incl. re-fill unit			
8 - 15 mm	19.000 N at 7 bar						
Item no. 320.753.000.000							

Spare / Wear Parts and Nosepieces

361.800.008.613	Mandrel M6
361.800.008.813	Mandrel M8
311.800.000.206	Nosepiece M6
311.800.000.208	Nosepiece M8
321.801.000.074	Lock nut M18x1
361.802.191.075	Lock nut M9x0,75

VNG 753



PNEUMATIC ACCESSORIES FOR BZ AND VNG TOOLS

Add to your order!

Have you considered the required pneumatic accessories? Save unnecessary expenditure and order the suitable accessories for the pneumatic tools of the BZ and VNG series with your tool purchase order!



No.	Description	Item no.
1	Angular pivoting fitting aluminium incl. hose with 1/4" outside thread and hose coupling	321.121.000.053-3-1
2	Pivoting threaded pipe angle, aluminium	321.121.000.053-1-1
3	Pivoting threaded pipe angle, stainless steel	321.121.000.053-2-1
4	Valve extension R1/8"	321.121.000.021
5	Screw-in hose connector -set- G 1/4" 6 mm	321.121.000.057
6	Screw-in hose connector -set- G 1/4" 9 mm	321.121.000.058
7a	Plug connection 7mm G 3/8 for compressed-air service unit	320.848.000.009
7b	Plug connection 7mm G 1/4 for pivoting threaded pipe angle	320.848.000.012
8	Coupling G 1/4"	320.848.000.010
9	Pressure controller 7 bar	320.848.000.004
10A	Compressed air spiral hose incl. coupling and plug connection -length 4m-	320.848.000.005
10B	Compressed air spiral hose incl. coupling and plug connection -length 6m-	320.848.000.006
10C	Compressed air spiral hose incl. coupling and plug connection -length 8m-	320.848.000.008
11	Oil re-fill unit for all tools of BZ- and VNG-series	321.101.006.467
12	Filter regulator G3/8 complete	320.848.000.001
13	Maintenance unit, 2-part, complete	320.848.000.002
---	Replacement filter for filter regulator	320.848.000.003
---	1 litre of pneumatic motor oil	320.848.000.011

For smooth operation of our pneumatic tools please note implicitly the information in our operating manuals! Important for preserving performance and to avoid damages are the **characteristics of the used compressed air**. Water condensation compromises the lubrication and causes corrosion inside the tool! The motors need to be greased continuously! **We recommend implicitly the use of maintenance units** for clean and greased air (VNG) or **filter-pressure reducers** for clean and dry air (BZ)!



Filter regulator G3/8 with filter-pressure regulator, manometer, plastic protective cage, fastening angle, plug connection G3/8 and coupling.



Maintenance unit G3/8, 2-part, including plastic protective cage, fastening angle, plug connection G3/8, coupling and 1 litre of pneumatic motor oil.

BZ.VNG.
DMSD2G
Process monitoring



- In-process monitoring of blind rivet and blind rivet nut setting operations
- Early detection of quality deviations
- Minimisation of QA effort
- Quick feedback through transparency in the production process
- Traceable process results
- Reduction in additional test routines.



For more than 25 years, DMSD has been synonymous with **process monitoring in fastener technology.**



Display module – DIM

DIM and MEM directly connected

Measurement recording module – MEM

The measurement recording module can be connected to the display module via a connecting cable with a maximum cable length of 5 m or can be plugged in directly.

Almost any distance between the modules can be realised by incorporating DIMs and MEMs in a company-provided Ethernet. Alternatively, the measurement recording module (MEM) is directly connected to the display module (DIM).

2G benefits at a glance

- Connection possibility for measurement transducers with different output signals from DMS to incremental and piezo measurement transducers without additional amplifiers.
- The resolution of the distance measurement has been improved from 0.1 mm to 0.01 mm. This therefore complies with the VDA demand for 10 times resolution when recording with regard to the evaluation.
- The facility for monitoring maximum force and two additional control windows has been supplemented by two freely parametrisable control windows, even to the extent of envelope curve monitoring. It is possible to evaluate up to 10 evaluation elements in one measuring program.
- Up to 108 measuring programs can be stored in the monitoring.
- Up to 20 master programs are available for the monitoring.
- Parametrisation and programming take place via the firmware installed in the controller – no additional program is required.
- Operation and remote maintenance is possible using a VPN tunnel via a VNC viewer. The persons involved can access the functions of the software via the Internet and monitor the actions. The VNC viewer can also be connected to a large monitor.
- The measurement evaluation module (MEM) can be used with the display module (DIM) or also as a black box module without a display module.

BZ.VNG. DMSD2G

Up to eight measurement recording modules can be connected to a display module for extended applications.

When using a VNC viewer, applications can also alternatively be implemented that do not have a display module.



Up to 8 MEMs can be connected to a DIM and displayed simultaneously.

As well as the last process values, a history of the previous setting processes can be called up via the MEM.

The process monitoring measuring programs and settings can be stored on a USB storage medium, from where they can also be restored.

The process values can be archived on a USB storage medium or on a server via Ethernet (USB storage medium, server or QDAS).

The process values can be stored in Q-DAS, XML, CSV, PDF, QDA-9 or IPM 5.0 format. Process values stored in CSV format can be subjected to further processing using Excel.

A scanner for recording the components can be directly attached to the MEM. If a scanner is incorporated, the code that is read in is also stored, making tracking possible.

Connection to a customer controller is possible via digital inputs and outputs and via a field bus (PROFINET, PROFIBUS DP and EtherCAT).

Connection option for hand-held tools

1. Hand scanner
2. USB storage medium
3. Server
4. Digital inputs (5x) and outputs (8x)
 - PROFINET
 - EtherCAT
 - PROFIBUS DP
5. RivSmart tools via WiFi
6. BZ and VNG components



Connection option for automatic units

1. Machine controller with PLC via digital inputs and outputs or fieldbus
2. Sensors for process monitoring
3. Communication: SPS <-> MEM via digital inputs and outputs or fieldbus

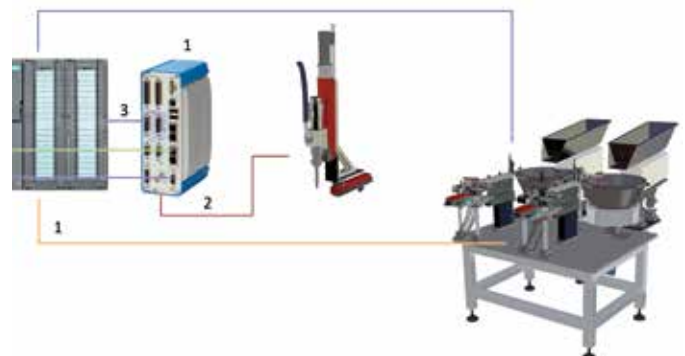

Connection between MEM and programming user interface

1. MEM fitted directly on DIM.
2. Distance between DIM and MEM up to 5 m via cable.
3. Operation via DIM connected via Ethernet.
4. Operation with VNC viewer on machine control unit via Ethernet.
5. Operation with VNC viewer on PC via Ethernet.
6. Remote maintenance via Internet and VPN.

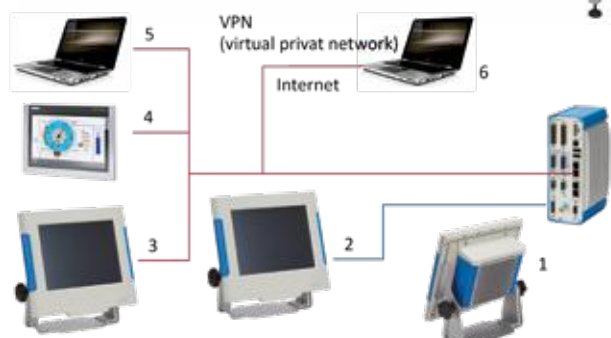

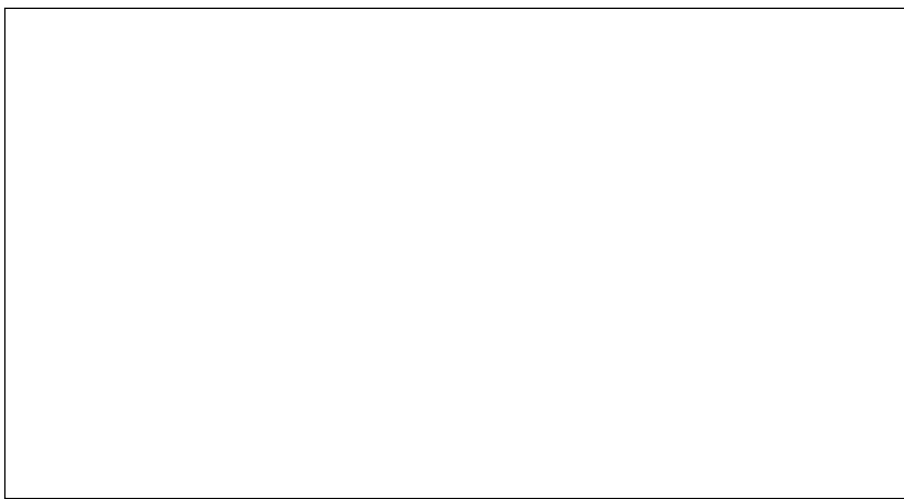

Price 3.00 €

All prices exclusive of VAT.

Subject to technical and editorial changes.